

# The Backlash-free Safety Clutch for

*Packaging Machinery  
Machine Tools  
Paper Machinery  
Indexing Drives  
Servo Motors*



## **EAS<sup>®</sup> -NC**

*Backlash-free Safety Clutch*

- *Indicating torque adjustment*
- *Easy assembly*
- *Hardened functional components*
- *Synchronous and Ratchetting design*

[www.mayr.de](http://www.mayr.de)

K.405.V06.GB

**mayr**<sup>®</sup>  
power-  
transmission

## EAS<sup>®</sup>-NC Clutches optimum overload protection for your machinery.

EAS<sup>®</sup>-NC Torque Limiting Clutches guarantee economic protection and reliable operation, in order to maximise utilisation of machinery and equipment.

The continually increasing electric requirements in the power transmission for dynamics, higher speeds and accuracy can be met by using EAS<sup>®</sup>-NC Clutches.

With its optimum design principles and simple mechanics, EAS<sup>®</sup>-NC Clutches can withstand the extreme operating conditions. EAS<sup>®</sup>-NC Clutches provide zero backlash torque transmission characteristics and limit the transmitted torque exactly to a pre-set value.

In case an overload condition occurs in the drive train, due to a blockage or collision for example, the clutch will disengage, disconnecting input and output, thus uncoupling up to 90 % of the damaging energy in the system, which, if not disconnected, would cause costly damage and down-time to the machine.

### Advantages for your application

The EAS<sup>®</sup>-NC Torque Limiting Clutch is the ideal overload protection for your machine:

- Precise torque limitation prevents costly downtime and repairs in the event of an overload.
- Backlash-free torque transmission guarantees the highest drive accuracy and service life.
- Backlash-free function remains throughout the machine's life.
- High speed and high acceleration obtained through low inertia design.
- Immediate disconnection of input and output drive components prevents costly machine damage.
- The versatility of the design ensures a suitable solution for every application.
- Graduated torque setting eliminates operating errors.
- Low operating expenses through a maintenance-free principle.
- Immediate readiness for use after an overload has occurred, minimising machine downtime.

### Please Observe:

According to Germany notation, decimal point in this document are represented with a comma. (e.g. 0,5 instead of 0.5)

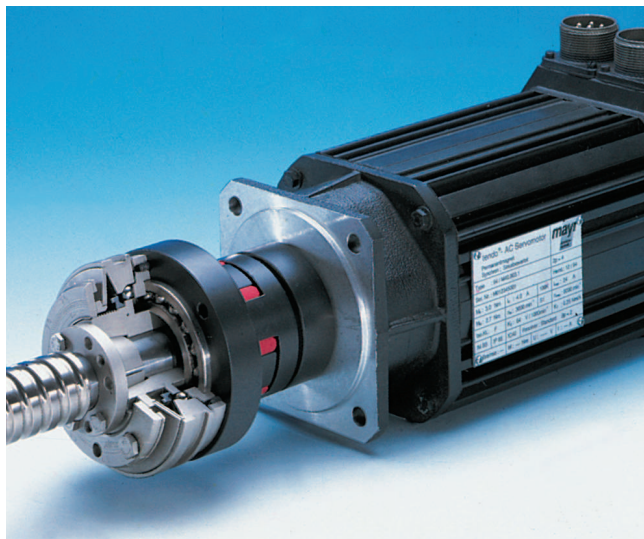

EAS<sup>®</sup>-NC Lastic Backlash-free version in a directly driven servo axis. This combination limits the torque precisely to the pre-set value, compensates for shaft misalignments and damps critical vibrations.

### Fast mechanical torque limiting even with electronic current monitoring systems.

Although most modern electronic systems are used for control and monitoring, blockages and collisions cannot be completely prevented. False initial start programming errors or operating errors outwit the most sophisticated control concepts. Modern electronic controls are designed with an excess-current release, which should prevent damage due to operating errors.

This type of overload protection has a considerable disadvantage which can be compensated for by a fast mechanical torque limiting safety clutch. Valuable time is lost between collision occurring until the drive motor or equipment is switched off. If a blockage occurs in the drive line the torque increases together with the motor current, and the whole drive system becomes tensioned. This overload situation can cause acute instantaneous damage before the control system registers the current rise and switches off the drive.

This gives the EAS<sup>®</sup>-NC Torque Limiting Clutch with its mechanical overload protection a decisive advantage. The damaging kinetic energies are uncoupled and released already within a few milliseconds and, as a limit switch can detect the disengaging movement of the clutch, a signal can be used to completely stop the machine or equipment.



## Save time on selection and construction

Reduce your costs for product selection and construction to a minimum using our CD-ROM (**mayr®**-ROM) or our internet page ([www.mayr.de](http://www.mayr.de)), with:

- selection programme
- documentation as PDF
- CAD drawings as DXF and
- queries or order possibilities

Please visit our internet page ([www.mayr.de](http://www.mayr.de)) or ask for our CD-ROM (**mayr®**-ROM)!  
Telephone 08341/804-0.



## Quality, experience, competence

**mayr®**-drive technology has set the standards for innovative and technically economical solutions for decades. The reasons for this success are, as well as many other factors, the highest product quality and the highly-developed quality consciousness of our employees.

Our certification according to DIN EN ISO 9001:2000 and DIN EN ISO 14001 confirm the high demands which we place upon ourselves. With our polished quality management, our renowned high product quality, our years of experience and the know-how gathered during this time, we are able to offer you comprehensive competence worthy of your trust in the fields of mechanics and electronics.



## Further products in the EAS®-programme:

### EAS®-Compact-R

Only corrosion-protected safety clutches are suitable for critical conditions with wet ambient conditions or aggressive mediums. Our product selection ranges from open designs made of stainless steel to sealed, rust-proof clutches or units for integration between the motor and the gearbox.

### EAS®-Sp / EAS®-Sm / EAS®-Zr

Pneumatically or electromagnetically controlled torque limiting clutches with a complete disengage, remote-control on-off clutching function. Torque adjustable to suit varied operating conditions.

### EAS®-element clutch / EAS®-element

EAS®-element based EAS®-element clutches for high torque applications (0,25–190 kNm). Basic elements can be integrated into existing constructions and offer flexibility of design to suit specific applications.

### EAS®-axial

Linear motion overload protection. Tensile and compressive forces monitored via unique compact mechanical element. Eight sizes cover forces between 50 and 300 000 N in 12 variations in type and design.

**Indicated torque adjustment**

- ❑ The torque can be adjusted sensitively and accurately indicated by the fine pitch threaded graduated adjusting nut.
- ❑ The positive locking of the adjusting nut protects against self-acting unintended adjustment of the pre-set limiting torque. For the NC-sizes 4 to 6 there is an additional mechanical lock and back drive locking.

**Torque limitation**

- ❑ Adjustable torques are transmitted via balls placed in two geometrical defined seats from hub to pressure flange.
- ❑ The balls ratchet out of seats when the pre-set limiting torque is exceeded.

**Pressure flange**

- ❑ Axially and radially supported by a deep groove ball bearing.
- ❑ Precise connection and axial location of the drive element.

**Easy torque adjustment**

**Limit switch**

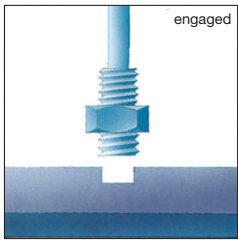

- ❑ Extreme short switch-off times
- ❑ Precise connection and axial point adjustment

**Signal usage**



- ❑ In the event of an overload the limit switch detects the axial disengaging movement of the thrust ring quickly and precisely.
- ❑ The limit switch gives a signal for switching off the drive or other control function.

**engaged**

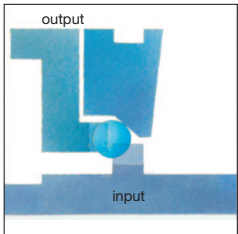

**disengaged**

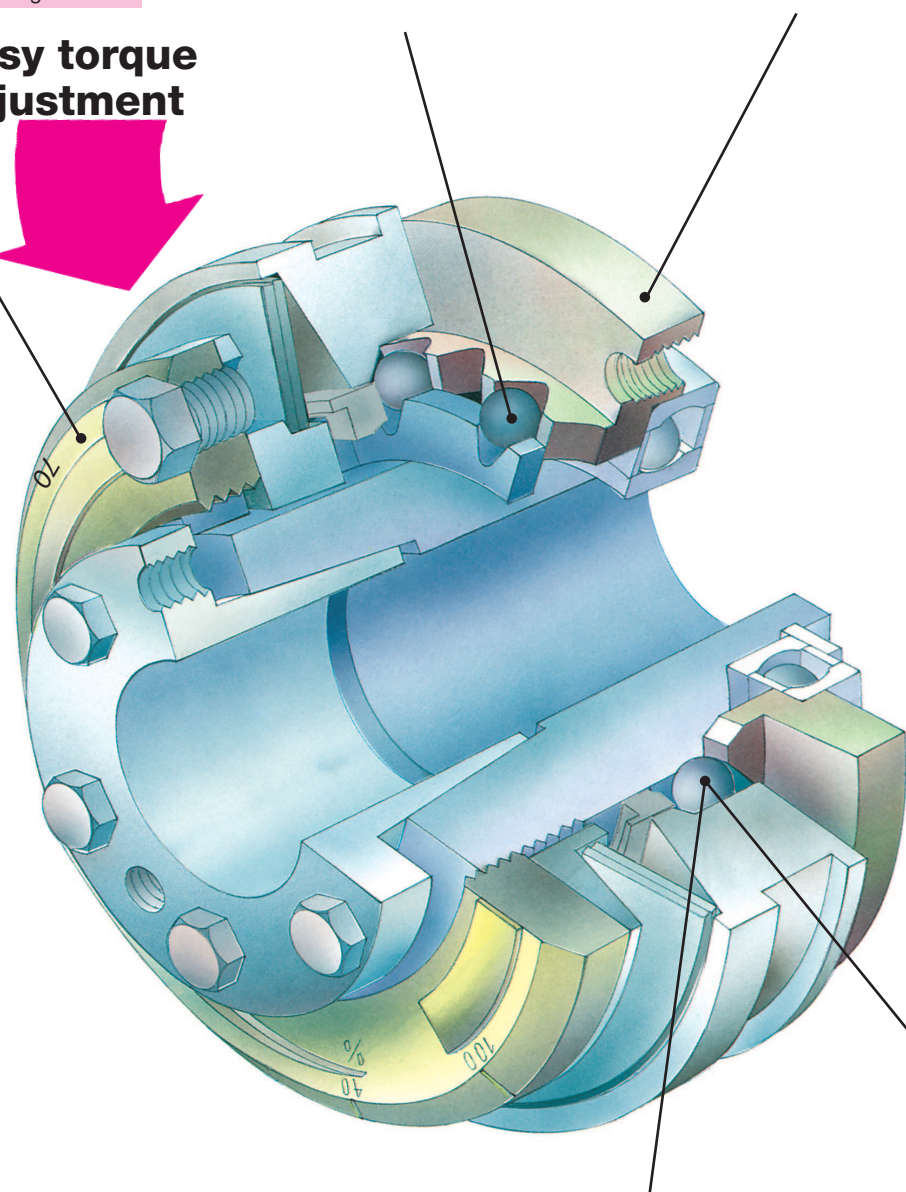
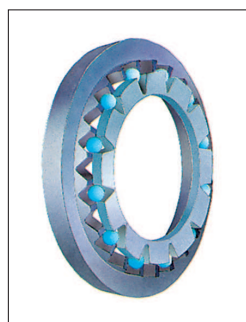
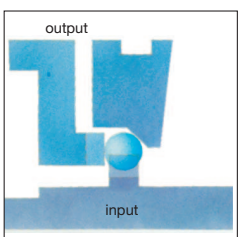

**The patented backlash-free principle**

The backlash-free torque transmission

- ❑ Balls located in **radially and axially arranged recesses** on the hub and pressure flange.
- ❑ The balls are pressed by the thrust ring **simultaneously into the recesses of the hub and pressure flange** and, therefore, transmit the torque backlash-free in both directions of rotation, even with reversing direction of rotation.
- ❑ Consistent and precise torque decrease in the event of an overload due to *mayr*<sup>®</sup> cup springs with degressive spring characteristic.

# EAS<sup>®</sup>-NC torque limiting clutch

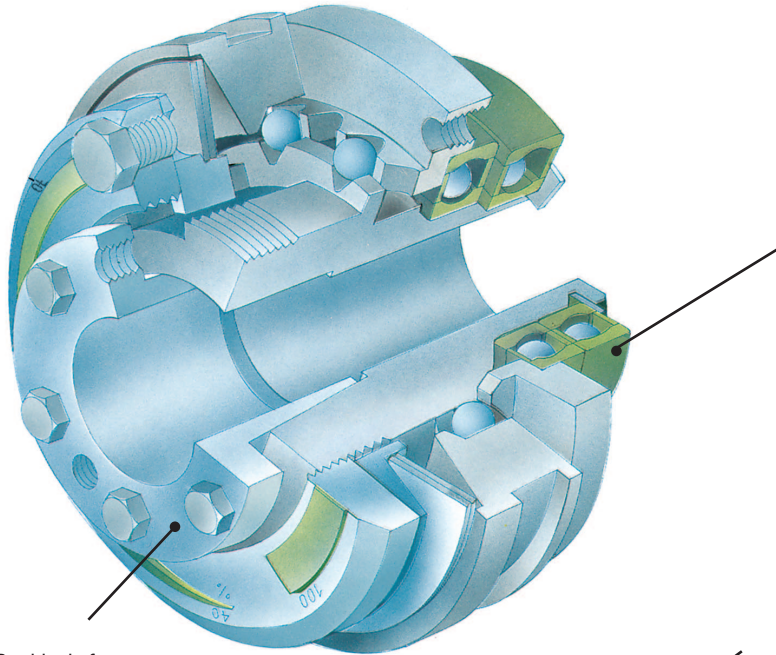

Backlash-free shaft-hub connection via cone bushing

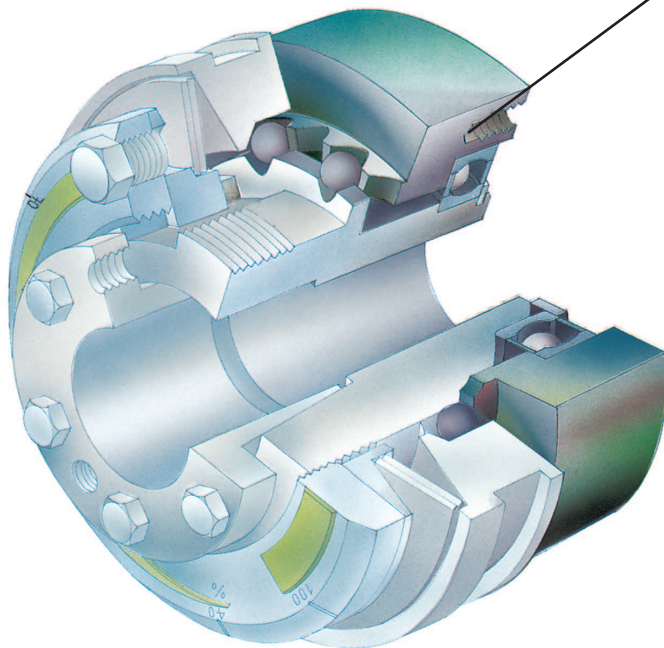

## EAS<sup>®</sup>-NC variations

### EAS<sup>®</sup>-NC Type 450 Design .2

Clutch with special hub variations for fitting of wide drive elements to customer requirements.

- Stable double bearing
- Ready for attachment
- High degree of true running accuracy

### EAS<sup>®</sup>-NC Type 451

The EAS<sup>®</sup>-NC principle with the mounting dimensions of our well proven EAS<sup>®</sup>-Type series 400.

- Backlash-free
- Roller bearing in the pressure flange
- High degree of switching-off accuracy
- Degressive spring characteristic

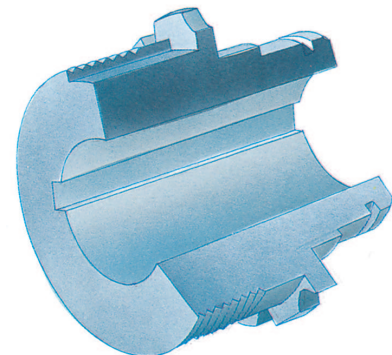

EAS<sup>®</sup>-NC hub with positive shaft-hub connection

## EAS<sup>®</sup>-NC - the backlash-free principle

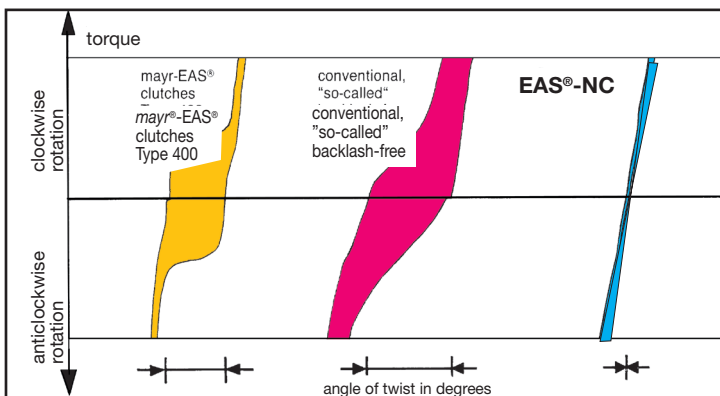

### Backlash is:

- The angular tolerance between input and output clutch components.
- Also known as circumferential backlash.
- Not to be mistaken for transmitting backlash from shaft to hub.
- With mayr<sup>®</sup> backlash-free means: backlash → 0 (see graph).**



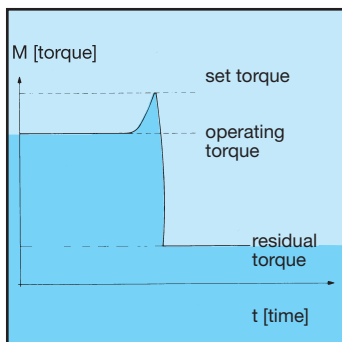

Switching behaviour

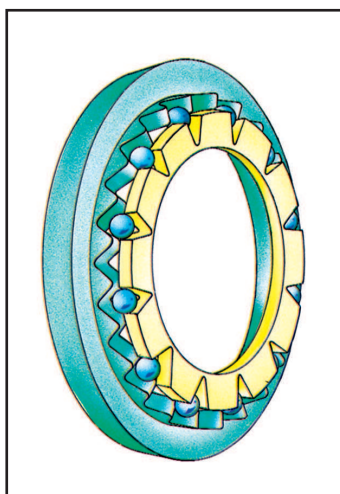

## Operating principle of the mayr<sup>®</sup>-EAS<sup>®</sup>-NC ratchetting clutch

- ❑ When the pre-set limiting torque is achieved, the torque drops immediately.
- ❑ The EAS<sup>®</sup>-NC ratchetting clutch ratchets and re-engages automatically at the next convenient ball detent after removal of the overload.
- ❑ The mayr<sup>®</sup> limit switch switches off the drive immediately
- ❑ or makes another control function.

## The backlash-free torque transmitting safety clutch

- ❑ Uniform and constant torque transmission due to precision manufacture of the ball detents.
- ❑ Clean and precise torque adjustment due to graduated, readable adjusting nut.
- ❑ In the event of an overload:
  - \* rapid torque decrease
  - \* signal for equipment control
- ❑ The EAS<sup>®</sup>-NC ratchetting clutch guarantees an immediate readiness for operation of the machine and equipment after removal of the overload.
- ❑ Reliable collision protection e.g. in feed drives of machine tools.

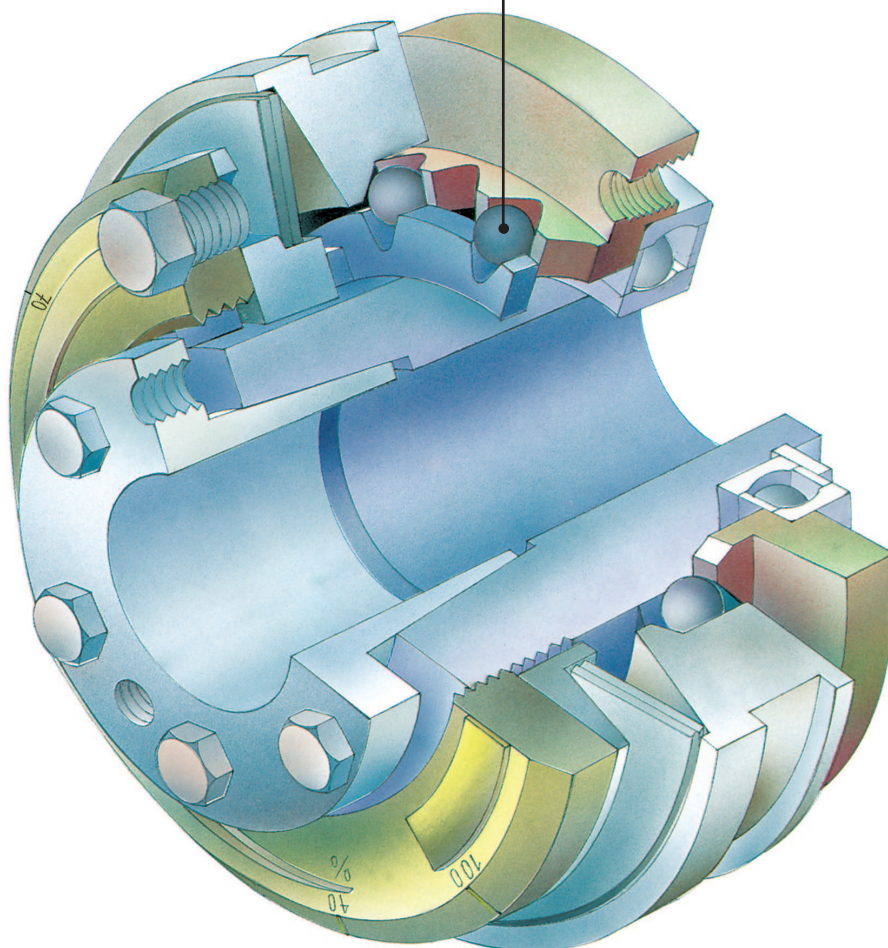

## EAS<sup>®</sup>-NC synchronous clutch

### Operating principle of the mayr<sup>®</sup>-EAS<sup>®</sup>-NC synchronous clutch

- ❑ The EAS<sup>®</sup>-NC synchronous clutch disengages when the pre-set limiting torque is achieved.
- ❑ After removal of the overload the clutch re-engages automatically synchronously at 360°. Other cycles, for example 180°, are also available.

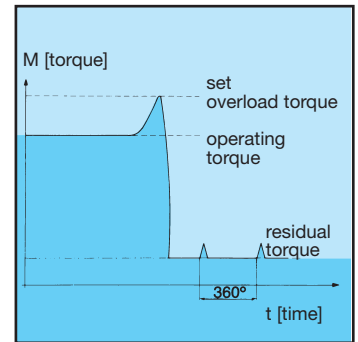
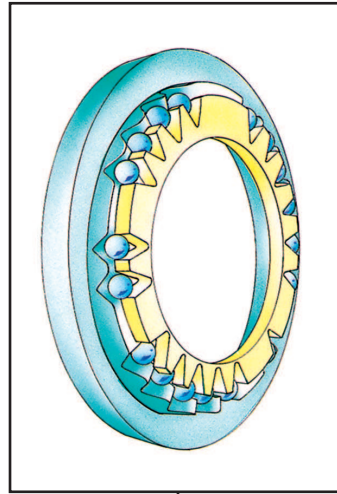

switching behaviour

- ❑ Re-engagement is only guaranteed at a certain position due to the special *mayr*<sup>®</sup> synchronous geometry of the *mayr*<sup>®</sup>-precision balls and ball detents.
- ❑ Uniform and constant torque transmission.
- ❑ Versatile tuning controls for cycles are possible, for example
  - \* transfer points
  - \* feed systems
  - \* handling systems.
- ❑ Clean and precise torque adjustment due to graduated, readable adjusting nut.
- ❑ In the event of an overload:
  - \* immediate torque reduction
  - \* control signal
  - \* synchronous re-engagement
  - \* reliable collision and overload protection

### mayr<sup>®</sup>-EAS<sup>®</sup>-NC safety clutch in machines and equipment

- reduces downtimes
- increases availability
- increases productivity

#### a safety advantage for

- ... persons
- ... machines
- ... controls

## Summary of types

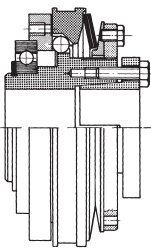
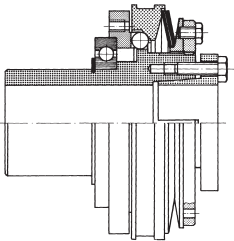
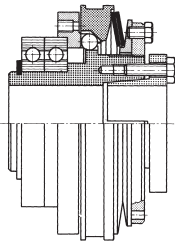
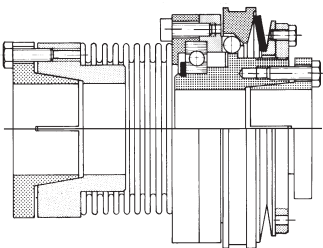
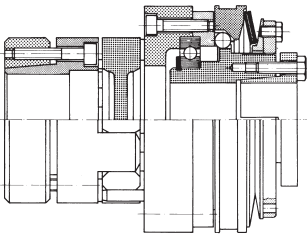
EAS <sup>®</sup> -NC clutch	Type Size	Torque [Nm]	Application
<p><b>EAS<sup>®</sup>-NC short hub</b></p> 	450._._.0 Sizes 03 – 3	0,65 – 450	<p>Flanged torque limiting clutch backlash-free torque transmission between shaft and drive element. The torque is transmitted backlash-free until disengagement and reduces immediately when an overload occurs. Low mass moment of inertia. Automatic re-engagement. Long working life.</p> <p>Page 10 with cone bushing Type 450._1_.0 Page 11 with keyway Type 450._2_.0</p>
<p><b>EAS<sup>®</sup>-NC long projecting hub</b></p> 	450._._.1 Sizes 03 – 3	0,65 – 450	<p>Flanged torque clutch for backlash-free torque transmission between shaft and drive element. The torque is transmitted backlash-free until disengagement and reduces immediately when an overload occurs. Additional location of wide drive elements on a long hub through roll and slide bearing is possible. Low mass moment of inertia. Automatic re-engagement. Long working life.</p> <p>Page 12 with cone bushing Type 450._1_.1 Page 13 with keyway Type 450._2_.1</p>
<p><b>EAS<sup>®</sup>-NC two-bearings design</b></p> 	450._._.2 Sizes 03 – 3	0,65 – 450	<p>Flanged torque limiting clutch for backlash-free torque transmission between shaft and drive element. The torque is transmitted backlash-free until disengagement and reduces immediately when an overload occurs. EAS<sup>®</sup>-NC two-bearings version for direct stable location of the drive elements on the clutch, Low mass moment of inertia. Automatic re-engagement. Long working life.</p> <p>Page 14 with cone bushing Type 450._1_.2 Page 15 with keyway Type 450._2_.2</p>
<p><b>EAS<sup>®</sup>-NC with steel bellows coupling</b></p> 	453._._.0 Sizes 03 – 3	0,65 – 450	<p>Torque limiting clutch for backlash-free torque transmission between two coaxial shafts. The torque is transmitted backlash-free until disengagement and reduces immediately when an overload occurs. Low mass moment of inertia. Automatic re-engagement. Compensates axial, radial and angular misalignments. Long working life.</p> <p>Page 16 with cone bushing Type 453._1_.0 Page 17 with keyway Type 453._2_.0 Page 18 with cone bushing/clamping hub Type 453._3_.0</p>
<p><b>EAS<sup>®</sup>-NC lastic backlash-free</b></p> 	454._._._ Sizes 01 – 3	4 – 450,	<p>Torque limiting clutch for flexible, backlash-free torque transmission between two coaxial shafts. The torque is transmitted backlash-free until disengagement and reduces immediately when an overload occurs. Automatic re-engagement. Compensates axial, radial and angular misalignments. High degree of damping characteristic - Long service life.</p> <p>Page 19 with cone bushing/clamping hub Type 454._0_._ Page 20 with cone bushing/shrink disc Type 454._1_._ Page 21 with keyway Type 454._2_._</p>



# EAS<sup>®</sup>-NC ratchetting clutch/synchronous clutch

## Summary of types

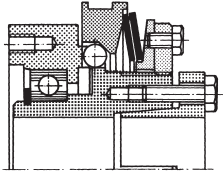
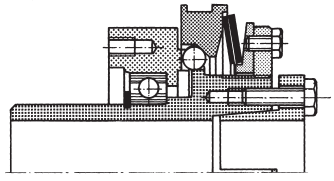
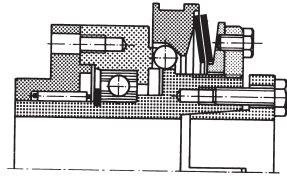
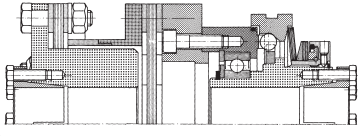
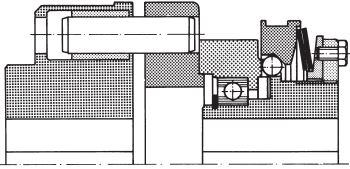
EAS <sup>®</sup> -NC clutch	Type Size	Torque [Nm]	Application
<b>EAS<sup>®</sup>-NC short hub with fitting dimensions of the type series 400</b> 	451.____.0 Sizes 01 – 6	4 – 2400	Flanged torque limiting clutch for backlash-free torque transmission between shaft and drive element. The torque is transmitted backlash-free until disengagement and reduces immediately when an overload occurs. Low mass moment of inertia. Automatic re-engagement. Long working life.
			<a href="#">Page 22</a> with cone bushing Type 451._1_.0 <a href="#">Page 23</a> with keyway Type 451._2_.0
<b>EAS<sup>®</sup>-NC with long projecting hub and fitting dimensions of the type series 400</b> 	451.____.1 Sizes 01 – 6	4 – 2400	Additional location of wide drive elements on a long hub through roll and slide bearing is possible. Low mass moment of inertia. Automatic re-engagement. Long working life.
			<a href="#">Page 24</a> with cone bushing Type 451._1_.1 <a href="#">Page 25</a> with keyway Type 451._2_.1
<b>EAS<sup>®</sup>-NC with short supported hub and fitting dimensions of the type series 400</b> 	451.____.5 Sizes 01 – 3	4 – 450	Simple symmetrical and narrow drive elements can be fitted without additional support bearing due to the integrated bearing. Low mass moment of inertia. Automatic re-engagement. Long working life.
			<a href="#">Page 26</a> with cone bushing Type 451._1_.5 <a href="#">Page 27</a> with keyway Type 451._2_.5
<b>EAS<sup>®</sup>-NC torsionally rigid</b> 	456.____.8 Sizes 4 – 6	75 – 2400	Torque limiting clutch for backlash-free torque transmission between two coaxial shafts. The torque is transmitted backlash-free until disengagement and reduces immediately when an overload occurs. High torsional stiffness. Long working life.
			<a href="#">Page 28</a> with cone bushing Type 456._1_.8 <a href="#">Page 29</a> with keyway Type 456._2_.8
<b>EAS<sup>®</sup>-NC lastic</b> 	457._2_.0 Sizes 01 – 3	4 – 450	Backlash-free torque limiting clutch combined with a torsionally flexible shaft coupling for connection two shafts. The flexible coupling section is designed as a simple slip-on coupling which allows an easy assembly and dismantling of the clutch. Long working life.
			<a href="#">Page 30</a> with keyway Type 457._2_.0
<b>Mounting examples and Technical explanations</b>			<a href="#">Page 31 – 35</a>
<b>Electrical accessories</b>			Limit switch <a href="#">Page 36 – 38</a>

## Short hub with cone bushing

Type 450.\_1\_.0

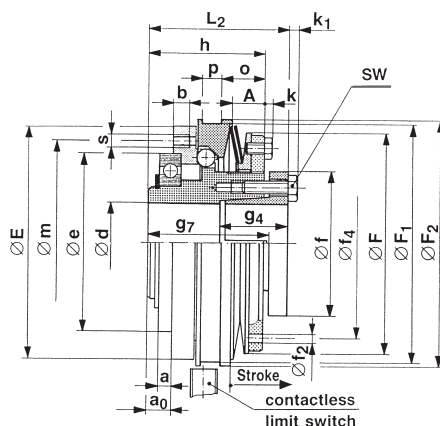

Sizes 03 – 3 Type 450.\_1\_.0

### Technical data

1) Size	Limiting torques for overload $M_G$ 1)			Max. speed $n_{max}$ rpm	Stroke of the thrust washer in the event of an overload mm	Mass moments of inertia I		Weight kg	Clamping bolts and tightening torques for $\varnothing d$	
	Type 450.51_.0 Nm	Type 450.61_.0 Nm	Type 450.71_.0 Nm			Hub side kgm <sup>2</sup>	Pressure flange side kgm <sup>2</sup>		mm	Nm
03	0,65 – 1,3	1,3 – 2,6	2 – 3,8	4000	0,8	0,000027	0,000008	0,18	4xM3	1
02	2 – 5	5 – 10	6 – 15	4000	1,0	0,000054	0,000018	0,28	4xM3	1
01	4 – 10	8 – 20	12 – 30	4000	1,2	0,00019	0,00006	0,55	4xM4	3
0	8 – 20	15 – 40	23 – 60	4000	1,5	0,00047	0,00018	0,94	6xM4	3
1	15 – 36	30 – 72	45 – 108	3000	1,8	0,00120	0,00039	1,63	6xM5	5,5
2	30 – 75	60 – 150	90 – 225	2500	2,0	0,00273	0,00077	3,03	6xM6	9,5
3	60 – 150	120 – 300	180 – 450	2000	2,2	0,00620	0,00173	3,95	8xM6	9,5

### Dimensions

Size	Bore $d$ 2) from – to mm	Min. shaft length		A 6)	a 7)	a <sub>0</sub>	b	E	e <sub>h5</sub> 8)	F
		g <sub>4</sub> mm	g <sub>7</sub> mm							
03	6 – 12	11,5	25,5	7,2	2	4,5	5	40	30	37
02	8 – 15	15,5	30,5	9,5	2	5	5	47	37	42
01	9 – 16	18	36	9,5	3	6	6	60	47	57
0	12 – 20	23	43	10,2	4	8	7	77	62	63
1	15 – 25	27	49	10,9	5	10	7,5	90	68	82
2	22 – 35	29	54	12,6	5	10	8,5	106	80	103
3	32 – 45	32	61	14,7	5	10	9,5	125	100	118,5

Size	F <sub>1</sub>	F <sub>2</sub>	f	f <sub>2</sub>	f <sub>4</sub>	h 6)	k	k <sub>1</sub>	L <sub>2</sub> 3)	m	o 6)	p	s	SW
03	– 4)	45	26	–	–	24	– 5)	2	28,5	35	– 4)	– 4)	6 x M3	5,5
02	– 4)	50	30	3	37	29	– 5)	2	34,5	42	– 4)	– 4)	6 x M3	5,5
01	– 4)	65	35	5	46	33	1,0 5)	2,8	41	53	– 4)	– 4)	6 x M4	7
0	75	80	39	5	50	41	1,3 5)	2,8	49	69	14,9	7,5	6 x M5	7
1	90	95	48	6	67	47	3,0	3,5	56	80	17,4	7,5	6 x M6	8
2	105	110	61	6	84	52	5,5	4	62	90	19,7	8	6 x M6	10
3	125	130	74	7	104	59	5,5	4	70	112	23,5	9	6 x M8	10

1) other sizes for lower and higher torques on request

2) shaft fit: up to  $\varnothing 38$  h<sub>8</sub>, above  $\varnothing 38$  h<sub>8</sub>

3) dimensions in an un-tightened condition (in tightened condition shorter)

4) thrust washer without keyway, limit switch is located at the control element-front face

5) countersunk screw with hexagon socket DIN 7991

6) the dimensions A; h; o refer to the hub edge

7) mounting tolerance +0,1

8) fit by the user H7

We reserve the right to make dimensional and design alterations.

### Order example:

To be included when ordering, please state:	Size	Type	Bore $\varnothing d$ H7	With limit switch
Order number:		<b>450._1_.0</b>		see pages 36–38

03 – 3 →

\* medium torque range. . . . . 5 →

\* high torque range. . . . . 6 →

\* max. torque range. . . . . 7 →

\* see technical data, limiting torque for overload  $M_G$

→ according to size

→ 0 ratchetting clutch

→ 5 synchronous clutch

**Example:** Order number 1 / 450.610.0 / 25 with limit switch 055.002.5

# EAS<sup>®</sup>-NC ratchetting clutch/synchronous clutch

Short hub with keyway

Type 450.\_2\_.0

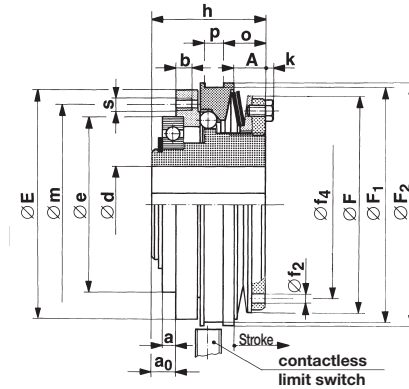

Sizes 03 – 3 Type 450.\_2\_.0

## Technical data

1) Size	Limiting torques for overload $M_G$ 1)			Max. speed $n_{max}$ rpm	Stroke of the thrust washer in the event of an overload mm	Mass moments of inertia I		Weight kg
	Type 450.52_0 Nm	Type 450.62_0 Nm	Type 450.72_0 Nm			Hub side kgm <sup>2</sup>	Pressure flange side kgm <sup>2</sup>	
03	0,65 – 1,3	1,3 – 2,6	2 – 3,8	4000	0,8	0,000025	0,000008	0,17
02	2 – 5	5 – 10	6 – 15	4000	1,0	0,000051	0,000018	0,26
01	4 – 10	8 – 20	12 – 30	4000	1,2	0,00018	0,00006	0,51
0	8 – 20	15 – 40	23 – 60	4000	1,5	0,00046	0,00018	0,89
1	15 – 36	30 – 72	45 – 108	3000	1,8	0,00117	0,00039	1,62
2	30 – 75	60 – 150	90 – 225	2500	2,0	0,00265	0,00077	2,86
3	60 – 150	120 – 300	180 – 450	2000	2,2	0,00602	0,00173	3,72

## Dimensions

Size	Bore		A 6)	a 7)	a <sub>0</sub>	b	E	e <sub>h5</sub> 8)	F
	d <sub>min</sub> mm	d <sub>max</sub> mm							
03	6	11	7,2	2	4,5	5	40	30	37
02	8	16 4)	9,5	2	5	5	47	37	42
01	9	20	9,5	3	6	6	60	47	57
0	12	20	10,2	4	8	7	77	62	63
1	15	25	10,9	5	10	7,5	90	68	82
2	22	35 5)	12,6	5	10	8,5	106	80	103
3	32	45	14,7	5	10	9,5	125	100	118,5

Size	F <sub>1</sub>	F <sub>2</sub>	f <sub>2</sub>	f <sub>4</sub>	h 6)	k	m	o 6)	p	s
03	– 2)	45	–	–	24	– 3)	35	– 2)	– 2)	6 x M3
02	– 2)	50	3	37	29	– 3)	42	– 2)	– 2)	6 x M3
01	– 2)	65	5	46	33	1 3)	53	– 2)	– 2)	6 x M4
0	75	80	5	50	41	1,3 3)	69	14,9	7,5	6 x M5
1	90	95	6	67	47	3,0	80	17,4	7,5	6 x M6
2	105	110	6	84	52	5,5	90	19,7	8	6 x M6
3	125	130	7	104	59	5,5	112	23,5	9	6 x M8

1) other sizes for lower and higher torques on request

2) thrust washer without keyway, limit switch is located at the control element-front facer

3) countersunk screw with hexagon socket DIN 7991

4) up to Ø 14 Nut keyway to DIN 6885/1, above Ø 14 keyway to DIN 6885/3

5) up to Ø 33 keyway to DIN 6885/1, above Ø 33 keyway to DIN 6885/3

6) the dimensions A; h; o refer to the hub edge

7) mounting tolerance +0,1

8) fit by the user H7

We reserve the right to make dimensional and design alterations.

9) Position of the keyway to the mounting bore "s" in the pressure flange not defined. A defined position is possible on request.

## Order example:

To be included when ordering, please state:	Size	Type	Bore Ø d <sup>H7</sup>	With limit switch
Order number:		450._2_.0	9)	see pages 36–38

03 – 3 →

\* medium torque range . . . . . 5 →

\* high torque range . . . . . 6 →

\* max. torque range . . . . . 7 →

\* see technical data, limiting torque for overload  $M_G$

→ according to size

→ 0 ratchetting clutch

→ 5 synchronous clutch

**Example:** Order number 1 / 450.620.0 / 25 / 6885-1 with limit switch 055.002.5



Long projecting hub  
with cone bushing

Type 450.\_1\_.1

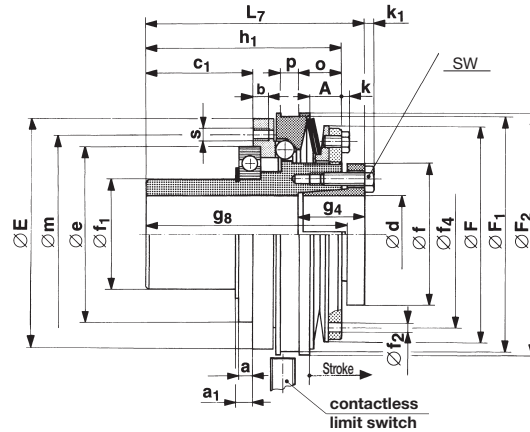

Sizes 03 – 3 Type 450.\_1\_.1

## Technical data

1) Size	Limiting torques for overload $M_G^{1)}$			Max. speed $n_{max}$ rpm	Stroke of the thrust washer in the event of an overload mm	Mass moments of inertia I		Weight kg	Clamping bolts and tightening torques for $\varnothing d$	
	Type 450.51_.1 Nm	Type 450.61_.1 Nm	Type 450.71_.1 Nm			Hub side kgm <sup>2</sup>	Pressure flange side kgm <sup>2</sup>		mm	Nm
03	0,65 – 1,3	1,3 – 2,6	2 – 3,8	4000	0,8	0,000028	0,000008	0,20	4xM3	1
02	2 – 5	5 – 10	6 – 15	4000	1,0	0,000058	0,000018	0,32	4xM3	1
01	4 – 10	8 – 20	12 – 30	4000	1,2	0,00019	0,00006	0,63	4xM4	3
0	8 – 20	15 – 40	23 – 60	4000	1,5	0,00050	0,00018	1,11	6xM4	3
1	15 – 36	30 – 72	45 – 108	3000	1,8	0,00126	0,00039	1,78	6xM5	5,5
2	30 – 75	60 – 150	90 – 225	2500	2,0	0,00287	0,00077	3,45	6xM6	9,5
3	60 – 150	120 – 300	180 – 450	2000	2,2	0,00676	0,00173	5,03	8xM6	9,5

## Dimensions

Size	Bore $d^{2)}$ from – to mm	Min. shaft length		A <sup>6)</sup>	a <sup>7)</sup>	a <sub>1</sub>	b	c <sub>1</sub>	E	e <sub>h5</sub> <sup>8)</sup>	F
		g <sub>4</sub> mm	g <sub>8</sub> mm								
03	6 – 12	11,5	41,5	7,2	2	3,0	5	20,5	40	30	37
02	8 – 15	15,5	50,5	9,5	2	3,2	5	25	47	37	42
01	9 – 16	18	61	9,5	3	4,2	6	31	60	47	57
0	12 – 20	23	70	10,2	4	5,5	7	35	77	62	63
1	15 – 25	27	79	10,9	5	6,75	7,5	40	90	68	82
2	22 – 35	29	92	12,6	5	7,0	8,5	48	106	80	103
3	32 – 45	32	111	14,7	5	7,5	9,5	60	125	100	118,5

Size	F <sub>1</sub>	F <sub>2</sub>	f	f <sub>1h6</sub>	f <sub>2</sub>	f <sub>4</sub>	h <sub>1</sub> <sup>6)</sup>	k	k <sub>1</sub>	L <sub>7</sub> <sup>3)</sup>	m	o <sup>6)</sup>	p	s	SW
03	– <sup>4)</sup>	45	26	17	–	–	40	– <sup>5)</sup>	2	44,5	35	– <sup>4)</sup>	– <sup>4)</sup>	6 x M3	5,5
02	– <sup>4)</sup>	50	30	25	3	37	49	– <sup>5)</sup>	2	54,5	42	– <sup>4)</sup>	– <sup>4)</sup>	6 x M3	5,5
01	– <sup>4)</sup>	65	35	30	5	46	58	1 <sup>5)</sup>	2,8	66	53	– <sup>4)</sup>	– <sup>4)</sup>	6 x M4	7
0	75	80	39	35	5	50	68	1,3 <sup>5)</sup>	2,8	76	69	14,9	7,5	6 x M5	7
1	90	95	48	40	6	67	77	3,0	3,5	86	80	17,4	7,5	6 x M6	8
2	105	110	61	50	6	84	90	5,5	4	100	90	19,7	8	6 x M6	10

- 1) other sizes for lower and higher torques on request
- 2) shaft fit: up to  $\varnothing 38$  h<sub>6</sub>, above  $\varnothing 38$  h<sub>8</sub>
- 3) dimensions in an un-tightened condition (in tightened condition shorter)
- 4) thrust washer without keyway, limit switch is located at the control element-front face
- 5) countersunk screw with hexagon socket DIN 7991
- 6) the dimensions A; h<sub>1</sub>; o refer to the hub edge
- 7) mounting tolerance +0,1
- 8) fit by the user H7

We reserve the right to make dimensional and design alterations.

## Order example:

To be included when ordering, please state:	Size	Type	Bore $\varnothing d$ H7	With limit switch
Order number:		450._1_.1		see pages 36–38

- 03 – 3 → according to size  
 \* medium torque range . . . . . 5 → 0 ratchetting clutch  
 \* high torque range . . . . . 6 → 5 synchronous clutch  
 \* max. torque range . . . . . 7

\* see technical data, limiting torque for overload  $M_G$

**Example:** Order number 2 / 450.510.1 / 30 with limit switch 055.002.5

# EAS<sup>®</sup>-NC ratchetting clutch/synchronous clutch

Long projecting hub  
keyway

Type 450.\_2\_.1 with

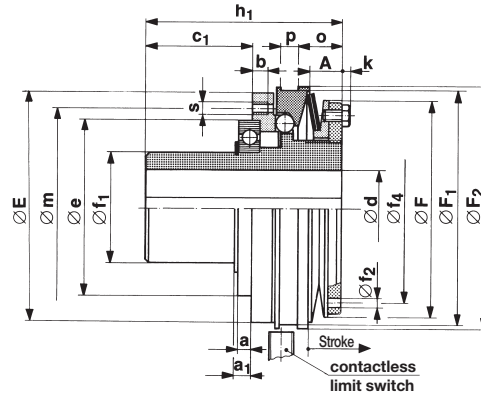

Sizes 03 – 3 Type 450.\_2\_.1

## Technical data

1) Size	Limiting torques for overload $M_G$ 1)			Max. speed $n_{max}$ rpm	Stroke of the thrust washer in the event of an overload mm	Mass moments of inertia I		Weight kg
	Type 450.52_.1 Nm	Type 450.62_.1 Nm	Type 450.72_.1 Nm			Hub side kgm <sup>2</sup>	Pressure flange side kgm <sup>2</sup>	
03	0,65 – 1,3	1,3 – 2,6	2 – 3,8	4000	0,8	0,000026	0,000008	0,19
02	2 – 5	5 – 10	6 – 15	4000	1,0	0,000055	0,000018	0,30
01	4 – 10	8 – 20	12 – 30	4000	1,2	0,00019	0,00006	0,59
0	8 – 20	15 – 40	23 – 60	4000	1,5	0,00049	0,00018	1,06
1	15 – 36	30 – 72	45 – 108	3000	1,8	0,00123	0,00039	1,77
2	30 – 75	60 – 150	90 – 225	2500	2,0	0,00279	0,00077	3,28
3	60 – 150	120 – 300	180 – 450	2000	2,2	0,00658	0,00173	4,80

## Dimensions

Size	Bore		A 6)	a 7)	a <sub>1</sub>	b	c <sub>1</sub>	E	e <sub>h5</sub> 8)	F
	d <sub>min</sub> mm	d <sub>max</sub> mm								
03	6	11	7,2	2	3,0	5	20,5	40	30	37
02	8	16 4)	9,5	2	3,2	5	25	47	37	42
01	9	20	9,5	3	4,2	6	31	60	47	57
0	12	20	10,2	4	5,5	7	35	77	62	63
1	15	25	10,9	5	6,75	7,5	40	90	68	82
2	22	35 5)	12,6	5	7,0	8,5	48	106	80	103
3	32	45	14,7	5	7,5	9,5	60	125	100	118,5

Size	F <sub>1</sub>	F <sub>2</sub>	f <sub>1</sub> h6	f <sub>2</sub>	f <sub>4</sub>	h <sub>1</sub> 6)	k	m	o 6)	p	s
03	– 2)	45	17	–	–	40	– 3)	35	– 2)	– 2)	6 x M3
02	– 2)	50	25	3	37	49	– 3)	42	– 2)	– 2)	6 x M3
01	– 2)	65	30	5	46	58	1 3)	53	– 2)	– 2)	6 x M4
0	75	80	35	5	50	68	1,3 3)	69	14,9	7,5	6 x M5
1	90	95	40	6	67	77	3,0	80	17,4	7,5	6 x M6
2	105	110	50	6	84	90	5,5	90	19,7	8	6 x M6
3	125	130	65	7	104	109	5,5	112	23,5	9	6 x M8

1) other sizes for lower and higher torques on request

2) thrust washer without keyway, limit switch is located at the control element-front face

3) countersunk screw with hexagon socket DIN 7991

4) up to Ø 14 keyway to DIN 6885/1, above Ø 14 keyway to DIN 6885/3

5) up to Ø 33 keyway to DIN 6885/1, above Ø 33 keyway to DIN 6885/3

6) the dimensions A; h<sub>1</sub>; o refer to the hub edge

7) mounting tolerance +0,1

8) fit by the user H7

We reserve the right to make dimensional and design alterations.

9) Position of the keyway to the mounting bore "s" in the pressure flange not defined. A defined position is possible on request.

## Order example:

To be included when ordering, please state:	Size	Type	Bore Ø d <sup>H7</sup>	With limit switch
Order number:		450._2_.1	9)	see pages 36–38

03 – 3 →

\* medium torque range. . . . . 5 →

\* high torque range. . . . . 6 →

\* max. torque range. . . . . 7 →

→ according to size

→ 0 ratchetting clutch

→ 5 synchronous clutch

\* see technical data, limiting torque for overload  $M_G$

**Example:** Order number 2 / 450.520.1 / 30 / 6885-1 with limit switch 055.002.5

## Two-bearings design with cone bushing

Type 450.\_1\_.2

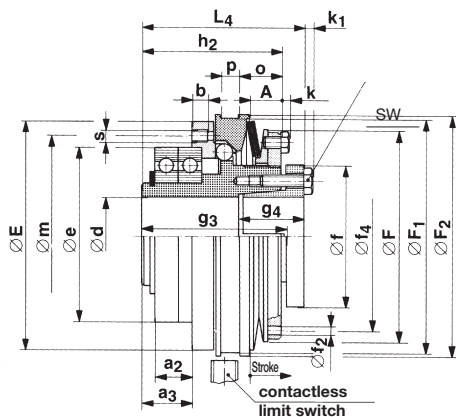

Sizes 03 – 3 Type 450.\_1\_.2

### Technical data

1) Size	Limiting torques for overload $M_G$ 1)			Max. speed $n_{max}$ rpm	Stroke of the thrust washer in the event of an overload mm	Mass moments of inertia $I$		Weight kg	Clamping bolts and tightening torques for $\varnothing d$	
	Type 450.51_.2 Nm	Type 450.61_.2 Nm	Type 450.71_.2 Nm			Hub side $kgm^2$	Pressure flange side $kgm^2$		mm	Nm
03	0,65 – 1,3	1,3 – 2,6	2 – 3,8	4000	0,8	0,000028	0,000008	0,13	4xM3	1
02	2 – 5	5 – 10	6 – 15	4000	1,0	0,000058	0,000018	0,31	4xM3	1
01	4 – 10	8 – 20	12 – 30	4000	1,2	0,000197	0,00006	0,60	4xM4	3
0	8 – 20	15 – 40	23 – 60	4000	1,5	0,000496	0,00018	1,03	6xM4	3
1	15 – 36	30 – 72	45 – 108	3000	1,8	0,00124	0,00039	1,74	6xM5	5,5
2	30 – 75	60 – 150	90 – 225	2500	2,0	0,00282	0,00077	3,20	6xM6	9,5
3	60 – 150	120 – 300	180 – 450	2000	2,2	0,00697	0,00173	4,24	8xM6	9,5

### Dimensions

Size	Bore $d$ 2) from – to mm	Min. shaft length		$A$ 6)	$a_2$ 7)	$a_3$	$b$	$E$	$e_{H5}$ 8)	$F$
		$g_3$ mm	$g_4$ mm							
03	6 – 12	32,5	11,5	7,2	9	11,5	5	40	30	37
02	8 – 15	37,5	15,5	9,5	9	12	5	47	37	42
01	9 – 16	45	18	9,5	12	15	6	60	47	57
0	12 – 20	52	23	10,2	13	17	7	77	62	63
1	15 – 25	58	27	10,9	14	19	7,5	90	68	82
2	22 – 35	64	29	12,6	15	20	8,5	106	80	103
3	32 – 45	72	32	14,7	16	21	9,5	125	100	118,5

Size	$F_1$	$F_2$	$f$	$f_2$	$f_4$	$h_2$ 6)	$k$	$k_1$	$L_4$ 3)	$m$	$o$ 6)	$p$	$s$	$SW$
03	– 4)	45	26	–	–	31	– 5)	2	35,5	35	– 4)	– 4)	6 x M3	5,5
02	– 4)	50	30	3	37	36	– 5)	2	41,5	42	– 4)	– 4)	6 x M3	5,5
01	– 4)	65	35	5	46	42	1,0 5)	2,8	50	53	– 4)	– 4)	6 x M4	7
0	75	80	39	5	50	50	1,3 5)	2,8	58	69	14,9	7,5	6 x M5	7
1	90	95	48	6	67	56	3,0	3,5	65	80	17,4	7,5	6 x M6	8
2	105	110	61	6	84	62	5,5	4	72	90	19,7	8	6 x M6	10
3	125	130	74	7	104	70	5,5	4	81	112	23,5	9	6 x M8	10

- 1) other sizes for lower and higher torques on request
- 2) shaft fit: up to  $\varnothing 38$   $H_8$ , above  $\varnothing 38$   $H_7$
- 3) dimensions in an un-tightened condition (in tightened condition shorter)
- 4) thrust washer without keyway, limit switch is located at the control element-front face
- 5) countersunk screw with hexagon socket DIN 7991
- 6) the dimensions  $A$ ;  $h_2$ ;  $o$  refer to the hub edge
- 7) mounting tolerance  $+0,1$
- 8) fit by the user H7

We reserve the right to make dimensional and design alterations.

### Order example:

To be included when ordering, please state:	Size	Type	Bore $\varnothing d$ H7	With limit switch
Order number:		450._1_.2		see pages 36–38

- 03 – 3 → according to size
- \* medium torque range. . . . . 5 → 0 ratchetting clutch
- \* high torque range. . . . . 6 → 5 synchronous clutch
- \* max. torque range. . . . . 7 →

\* see technical data, limiting torque for overload  $M_G$

**Example:** Order number 1 / 450.610.2 / 25 with limit switch 055.002.5



# EAS<sup>®</sup>-NC ratchetting clutch/synchronous clutch

Two-bearings design  
with keyway

Type 450. 2 .2

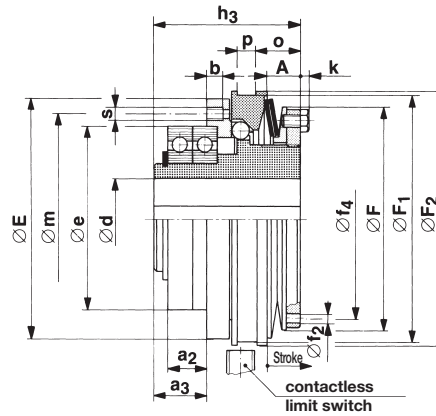

Sizes 03 – 3 Type 450. 2 .2

## Technical data

1) Size	Limiting torques for overload $M_G$ 1)			Max. speed $n_{max}$ rpm	Stroke of the thrust washer in the event of an overload mm	Mass moments of inertia I		Weight kg
	Type 450.52 .2 Nm	Type 450.62 .2 Nm	Type 450.72 .2 Nm			Hub side kgm <sup>2</sup>	Pressure flange side kgm <sup>2</sup>	
03	0,65 – 1,3	1,3 – 2,6	2 – 3,8	4000	0,8	0,000026	0,000008	0,18
02	2 – 5	5 – 10	6 – 15	4000	1,0	0,000055	0,000018	0,29
01	4 – 10	8 – 20	12 – 30	4000	1,2	0,000197	0,00006	0,56
0	8 – 20	15 – 40	23 – 60	4000	1,5	0,000496	0,00018	0,98
1	15 – 36	30 – 72	45 – 108	3000	1,8	0,00124	0,00039	1,73
2	30 – 75	60 – 150	90 – 225	2500	2,0	0,00282	0,00077	3,03
3	60 – 150	120 – 300	180 – 450	2000	2,2	0,00697	0,00173	4,01

## Dimensions

Size	Bore		A 6)	$a_2$ 7)	$a_3$	b	E	$e_{h5}$ 8)	F
	$d_{min}$ mm	$d_{max}$ mm							
03	6	11	7,2	9	11,5	5	40	30	37
02	8	16 4)	9,5	9	12	5	47	37	42
01	9	20	9,5	12	15	6	60	47	57
0	12	20	10,2	13	17	7	77	62	63
1	15	25	10,9	14	19	7,5	90	68	82
2	22	35 5)	12,6	15	20	8,5	106	80	103
3	32	45	14,7	16	21	9,5	125	100	118,5

Size	$F_1$	$F_2$	$f_2$	$f_4$	$h_3$ 6)	k	m	$o$ 6)	p	s
03	– 2)	45	–	–	31	– 3)	35	– 2)	– 2)	6 x M3
02	– 2)	50	3	37	36	– 3)	42	– 2)	– 2)	6 x M3
01	– 2)	65	5	46	42	1 3)	53	– 2)	– 2)	6 x M4
0	75	80	5	50	50	1,3 3)	69	14,9	7,5	6 x M5
1	90	95	6	67	56	3,0	80	17,4	7,5	6 x M6
2	105	110	6	84	62	5,5	90	19,7	8	6 x M6
3	125	130	7	104	70	5,5	112	23,5	9	6 x M8

- 1) other sizes for lower and higher torques on request
- 2) thrust washer without keyway, limit switch is located at the control element-front face
- 3) countersunk screw with hexagon socket DIN 7991
- 4) up to Ø 14 keyway to DIN 6885/1, above Ø 14 keyway to DIN 6885/3
- 5) up to Ø 33 keyway to DIN 6885/1, above Ø 33 keyway to DIN 6885/3
- 6) the dimensions A;  $h_3$ ; o refer to the hub edge
- 7) mounting tolerance +0,1
- 8) fit by the user H7

We reserve the right to make dimensional and design alterations.

- 9) Position of the keyway to the mounting bore "s" in the pressure flange not defined. A defined position is possible on request.

## Order example:

To be included when ordering, please state:	Size	Type	Bore Ø $d^{H7}$	With limit switch
Order number:		450. 2 .2	9)	see pages 36–38

- 03 – 3 →
- \* medium torque range . . . . . 5 →
- \* high torque range . . . . . 6 →
- \* max. torque range . . . . . 7 →
- \* see technical data, limiting torque for overload  $M_G$
- according to size
- 0 ratchetting clutch
- 5 synchronous clutch

**Example:** Order number 1 / 450.620.2 / 25 / 6885–1 with limit switch 055.002.5

**Steel bellows  
with cone bushing**

Type 453.\_1\_.0

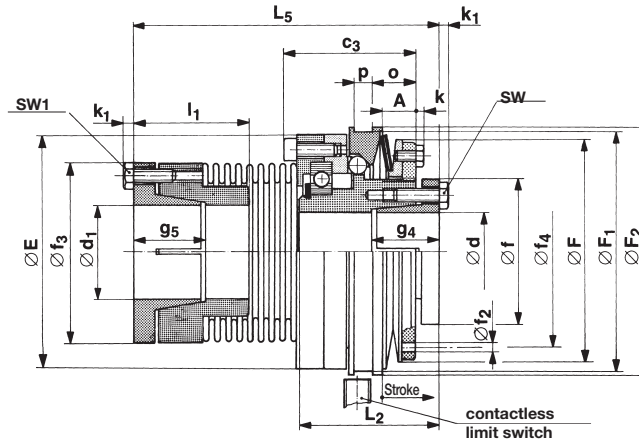

Sizes 03 – 3 Type 453.\_1\_.0

## Technical data

1) Size	Limiting torques for overload $M_G$ 1)			Nominal torque of flexible, torsionally rigid steel bellows coupling $T_{KN}$	Max. speed $n_{max}$ rpm	Stroke of the thrust washer in the event of an overload mm	Permissible flexibility		
	Type 453.51_.0 Nm	Type 453.61_.0 Nm	Type 453.71_.0 Nm				axial $\Delta K_a$ mm	angular $\Delta K_w$ °	radial $\Delta K_r$ mm
03	0,65 – 1,3	1,3 – 2,6	2 – 3,8	12	4000	0,8	0,2	2	0,1
02	2 – 5	5 – 10	6 – 15	25	4000	1,0	0,3	2	0,1
01	4 – 10	8 – 20	12 – 30	50	4000	1,2	0,4	2	0,15
0	8 – 20	15 – 40	23 – 60	100	4000	1,5	0,5	2	0,15
1	15 – 36	30 – 72	45 – 108	200	3000	1,8	0,8	2	0,2
2	30 – 75	60 – 150	90 – 225	350	2500	2,0	1,0	2	0,25
3	60 – 150	120 – 300	180 – 450	600	2000	2,2	1,2	2	0,3

Size	Mass moments of inertia $I$		Weight kg	Clamping bolts and tightening torques				Bore 2)		Min. shaft length	
	Hub side $kgm^2$	Flexible side $kgm^2$		at $\varnothing d$		at $\varnothing d_1$		d from-to mm	$d_1$ from-to mm	94 mm	95 mm
03	0,000027	0,000026	0,29	4 x M3	1,3	4 x M3	1,3	6 – 12	6 – 12	11,5	12,5
02	0,000054	0,000059	0,47	4 x M3	1,3	4 x M3	1,3	8 – 15	8 – 15	15,5	16
01	0,00019	0,00020	0,97	4 x M4	3	4 x M4	3	9 – 16	9 – 20	18	23,5
0	0,00047	0,00061	1,68	6 x M4	3	6 x M5	5,5	12 – 20	12 – 25	23	27
1	0,00120	0,00133	2,73	6 x M5	5,5	6 x M6	9,5	15 – 25	15 – 35	27	29
2	0,00273	0,00274	4,75	6 x M6	9,5	6 x M8	17	22 – 35	22 – 42	29	32
3	0,00620	0,00616	6,55	8 x M6	9,5	8 x M8	15	32 – 45	32 – 50	32	35

## Dimensions

Size	A 6)	$c_3$ 6)	E	F	$F_1$	$F_2$	f	$f_2$	$f_3$	$f_4$	k	$k_1$	$L_2$ 3)	$L_5$ 3)	$l_1$ 3)	$o$ 6)	p	SW	SW <sub>1</sub>
03	7,2	28	40	37	- <sup>5)</sup>	45	26	-	30	-	- <sup>5)</sup>	2	28,5	58,5	14	- <sup>4)</sup>	- <sup>4)</sup>	5,5	5,5
02	9,5	33,5	47	42	- <sup>5)</sup>	50	30	3	36	37	- <sup>5)</sup>	2	34,5	70,5	21	- <sup>4)</sup>	- <sup>4)</sup>	5,5	5,5
01	9,5	36,5	60	57	- <sup>5)</sup>	65	35	5	47	46	1,0 <sup>5)</sup>	2,8	41	85	27	- <sup>4)</sup>	- <sup>4)</sup>	7	7
0	10,2	48	77	63	75	80	39	5	58	50	1,3 <sup>5)</sup>	2,8	49	98	36	14,9	7,5	7	8
1	10,9	54	90	82	90	95	48	6	70	67	3,0	3,5	56	115	39	17,4	7,5	8	10
2	12,6	60	106	103	105	110	61	6	80	84	5,5	4	62	134	47	19,7	8	10	13
3	14,7	69	125	118,5	125	130	74	7	97	104	5,5	4	70	152	56	23,5	9	10	13

1) other sizes for lower and higher torques on request

We reserve the right to make dimensional and design alterations.

2) shaft fit: up to  $\varnothing 38 h_8$ , above  $\varnothing 38 h_8$

3) dimensions in an un-tightened condition (in tightened condition shorter)

5) countersunk screw with hexagon socket DIN 7991

4) thrust washer without keyway, limit switch is located at the control element-front face

6) the dimensions A; h; o refer to the hub edge

## Order example:

To be included when ordering, please state:	Size	Type	Bore $\varnothing d$ H7	Bore $\varnothing d_1$ H7	With limit switch
Order number:		<b>453._1_.0</b>			see pages 36–38

03 – 3 →  
 \* medium torque range . . . . . 5 →  
 \* high torque range . . . . . 6 →  
 \* max. torque range . . . . . 7 →  
 → according to size  
 → according to size  
 → 0 ratchetting clutch  
 → 5 synchronous clutch

\* see technical data, limiting torque for overload  $M_G$

**Example:** Order number 2 / 453.615.0 / 22/ 25 with limit switch 055.002.5

# EAS<sup>®</sup>-NC ratchetting clutch/synchronous clutch

Steel bellows with keyway

Type 453.\_2\_.0

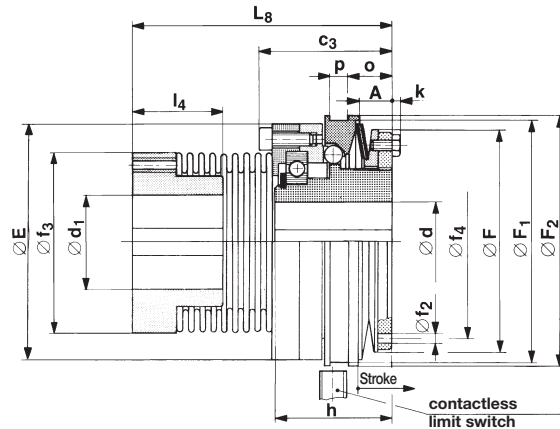

Sizes 03 – 3 Type 453.\_2\_.0

## Technical data

1) Size	Limiting torques for overload $M_G$ 1)			Nominal torque of flexible, torsionally rigid steel coupling $T_{KN}$	Max. speed $n_{max}$ rpm	Stroke of the thrust washer in the event of an overload mm	Permissible flexibility		
	Type 453.52_.0 Nm	Type 453.62_.0 Nm	Type 453.72_.0 Nm				axial $\Delta K_a$ mm	angular $\Delta K_w$ °	radial $\Delta K_r$ mm
03	0,65 – 1,3	1,3 – 2,6	2 – 3,8	12	4000	0,8	0,2	2	0,1
02	2 – 5	5 – 10	6 – 15	25	4000	1,0	0,3	2	0,1
01	4 – 10	8 – 20	12 – 30	50	4000	1,2	0,4	2	0,15
0	8 – 20	15 – 40	23 – 60	100	4000	1,5	0,5	2	0,15
1	15 – 36	30 – 72	45 – 108	200	3000	1,8	0,8	2	0,2
2	30 – 75	60 – 150	90 – 225	350	2500	2,0	1,0	2	0,25
3	60 – 150	120 – 300	180 – 450	600	2000	2,2	1,2	2	0,3

Size	Mass moments of inertia $I$		Weight kg	Bore			
	Hub side kgm <sup>2</sup>	Flexible side kgm <sup>2</sup>		$d_{min}$ mm	$d_{max}$ mm	$d_{1 min}$ mm	$d_{1 max}$ mm
03	0,000025	0,000026	0,29	6	11	6	11
02	0,000051	0,000059	0,47	8	16 <sup>4)</sup>	8	16 <sup>4)</sup>
01	0,00018	0,00020	0,97	9	20	9	20 <sup>6)</sup>
0	0,00046	0,00061	1,68	12	20	12	25 <sup>7)</sup>
1	0,00117	0,00133	2,73	15	25	15	35 <sup>5)</sup>
2	0,00265	0,00274	4,75	22	35 <sup>5)</sup>	22	42 <sup>8)</sup>
3	0,00602	0,00616	6,55	32	45	32	50

## Dimensions

Size	A <sup>9)</sup>	c <sub>3</sub> <sup>9)</sup>	E	F	F <sub>1</sub>	F <sub>2</sub>	f <sub>2</sub>	f <sub>3</sub>	f <sub>4</sub>	h	k	L <sub>8</sub> <sup>9)</sup>	l <sub>4</sub>	o <sup>9)</sup>	p
03	7,2	28	40	37	– <sup>2)</sup>	45	–	30	–	24	– <sup>3)</sup>	49,3	9,5	– <sup>2)</sup>	– <sup>2)</sup>
02	9,5	33,5	47	42	– <sup>2)</sup>	50	3	36	37	29	– <sup>3)</sup>	59	15	– <sup>2)</sup>	– <sup>2)</sup>
01	9,5	36,5	60	57	– <sup>2)</sup>	65	5	47	46	33	1,0 <sup>3)</sup>	69	25	– <sup>2)</sup>	– <sup>2)</sup>
0	10,2	48	77	63	75	80	5	58	50	41	1,3 <sup>3)</sup>	81	27	14,9	7,5
1	10,9	54	90	82	90	95	6	70	67	47	3,0	96	29	17,4	7,5
2	12,6	60	106	103	105	110	6	80	84	52	5,5	113	36	19,7	8
3	14,7	69	125	118,5	125	130	7	97	104	59	5,5	129	44	23,5	9

- 1) other sizes for lower and higher torques on request  
 2) thrust washer without keyway, limit switch is located at the control element-front face  
 3) countersunk screw with hexagon socket DIN 7991

- 4) up to Ø 14 keyway to DIN 6885/1, above Ø 14 keyway to DIN 6885/3  
 5) up to Ø 33 keyway to DIN 6885/1, above Ø 33 keyway to DIN 6885/3  
 6) up to Ø 18 keyway to DIN 6885/1, above Ø 18 keyway to DIN 6885/3  
 7) up to Ø 22 keyway to DIN 6885/1, above Ø 22 keyway to DIN 6885/3  
 8) up to Ø 38 keyway to DIN 6885/1, above Ø 38 keyway to DIN 6885/3  
 9) the dimensions A; c<sub>3</sub>; L<sub>8</sub>; o refer to the hub edge

We reserve the right to make dimensional and design alterations.

## Order example:

To be included when ordering, please state:	Size	Type	Bore $\varnothing d$ H7	Bore $\varnothing d_1$ H7	With limit switch
Order number:		453._2_.0			see pages 36–38

- 03 – 3 →  
 \* medium torque range ..... 5 →  
 \* high torque range ..... 6 →  
 \* max. torque range ..... 7 →  
 \* see technical data, limiting torque for overload  $M_G$   
 → according to size  
 → according to size  
 → 0 ratchetting clutch  
 → 5 synchronous clutch

**Example:** Order number 3 / 453.525.0 / 30 / 6885-1 / 40 / 6885-1 with limit switch 055.002.5



**EAS<sup>®</sup>-NC with steel bellows**  
**NC-side cone bushing**  
**bellows side clamping hub**

Type 453.\_3\_.0

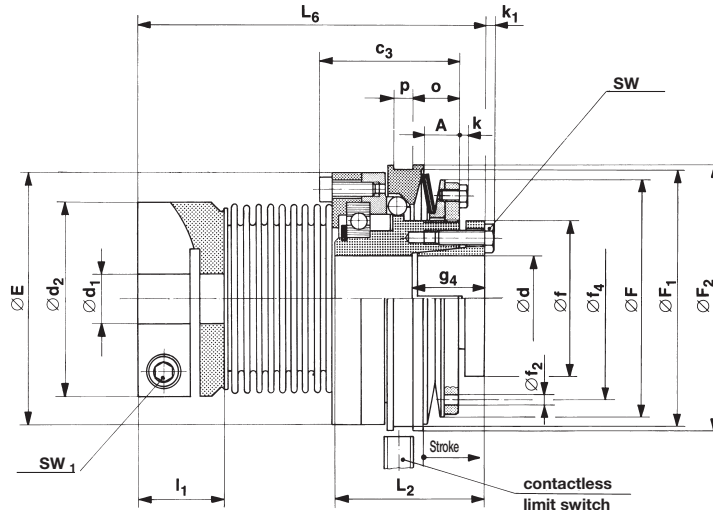

Sizes 0 – 3 Type 453.\_3\_.0

## Technical data

1) Size	Limiting torques for overload $M_G$ 1)			Nominal torque of flexible, torsionally rigid steel bellows coupling $T_{KN}$	Max. speed $n_{max}$ rpm	Stroke of the thrust washer in the event of an overload mm	Permissible flexibility		
	Type 453.53_.0 Nm	Type 453.63_.0 Nm	Type 453.73_.0 Nm				axial $\Delta K_a$ mm	angular $\Delta K_w$ °	radial $\Delta K_r$ mm
0	8 – 20	15 – 40	23 – 60	100	4000	1,5	0,5	2	0,15
1	15 – 36	30 – 72	45 – 108	200	3000	1,8	0,8	2	0,2
2	30 – 75	60 – 150	90 – 225	350	2500	2,0	1,0	2	0,25
3	60 – 150	120 – 300	180 – 450	600	2000	2,2	1,2	2	0,3

Size	Mass moments of inertia $I$		Weight kg	Clamping bolts and tightening torques				Bore		Min. shaft length	
	Hub side $kgm^2$	Flexible side $kgm^2$		SW		SW <sub>1</sub>		d <sup>2)</sup> from-to mm	d <sub>1</sub> from-to mm	g <sub>4</sub> mm	I <sub>1</sub> mm
0	0,00047	0,00061	1,68	6 x M4	3	M6	18	12 – 20	15 – 32	23	28
1	0,00120	0,00133	2,73	6 x M5	5,5	M6	18	15 – 25	25 – 42	27	28
2	0,00273	0,00274	4,75	6 x M6	9,5	M8	43	22 – 35	30 – 45	29	36
3	0,00620	0,00616	6,55	8 x M6	9,5	M10	87	32 – 45	35 – 55	32	40

## Dimensions

Size	A <sup>6)</sup>	c <sub>3</sub> <sup>6)</sup>	d <sub>2</sub>	E	F	F <sub>1</sub>	F <sub>2</sub>	f	f <sub>2</sub>	f <sub>4</sub>	k	k <sub>1</sub>	L <sub>2</sub> <sup>3)</sup>	L <sub>6</sub> <sup>3)</sup>	I <sub>1</sub>	o <sup>6)</sup>	p	SW	SW <sub>1</sub>
0	10,2	48	60	77	63	75	80	39	5	50	1,3 <sup>5)</sup>	2,8	49	108	28	14,9	7,5	7	5
1	10,9	54	71	90	82	90	95	48	6	67	3,0	3,5	56	122,5	28	17,4	7,5	8	5
2	12,6	60	82	106	103	105	110	61	6	84	5,5	4	62	146	36	19,7	8	10	6
3	14,7	69	98	125	118,5	125	130	74	7	104	5,5	4	70	165,5	40	23,5	9	10	8

1) other sizes for lower and higher torques on request

2) shaft fit: up to  $\varnothing 38 h_8$ , above  $\varnothing 38 h_8$

3) dimensions in an un-tightened condition (in tightened condition shorter)

5) countersunk screw with hexagon socket DIN 7991

6) the dimensions A; c<sub>3</sub>; o refer to the hub edge

We reserve the right to make dimensional and design alterations.

## Order example:

To be included when ordering, please state:	Size	Type	Bore $\varnothing d$ H7	Bore $\varnothing d_1$ H7	With limit switch
Order number:		<b>453._3_.0</b>			see pages 36–38

0 – 3 →  
 \* medium torque range. . . . . 5 →  
 \* high torque range. . . . . 6 →  
 \* max. torque range . . . . . 7 →  
 → according to size  
 → according to size  
 → 0 ratchetting clutch  
 → 5 synchronous clutch

\* see technical data, limiting torque for overload  $M_G$

**Example:** Order number 2 / 453.635.0 /22/ 30 with limit switch 055.002.5

# EAS<sup>®</sup>-NC ratchetting clutch/synchronous clutch

EAS<sup>®</sup>-NC with flexible backlash-free shaft coupling  
NC-side cone bushing  
bellows side clamping hub

Type 454.\_0.\_.

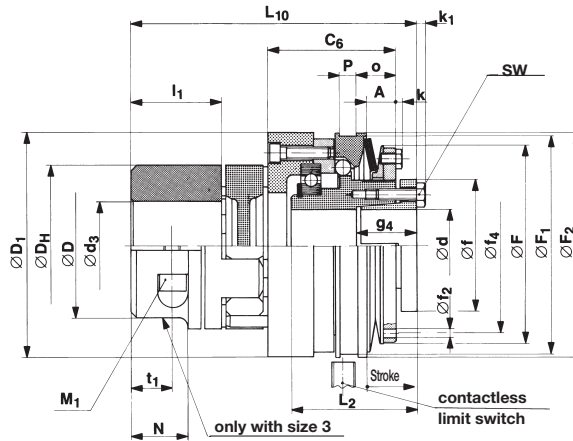

Sizes 01 – 3 Type 454.\_0.\_.

## Technical data

Size	Limiting torque for overload $M_G$		Nominal torque flexible, backlash-free shaft coupling $T_{KN}$ 1)						Max. speed $n_{max}$ rpm	Stroke of thrust washer in the event of an overload mm	Tightening torques clamping bolts $T_A$ at the diameter:		Weight kg
	Type 454.50_._	Type 454.60_._	92 Shore A		98 Shore A		64 Shore D				$\varnothing d$ Nm	$\varnothing d_3$ Nm	
	Nm	Nm	$T_{KN}$ Nm	$T_{KN max}$ Nm	$T_{KN}$ Nm	$T_{KN max}$ Nm	$T_{KN}$ Nm	$T_{KN max}$ Nm					
01	4 – 10	8 – 20	10	20	17	34	21	42	4000	1,2	3	10,5	0,95
0	8 – 20	15 – 40	35	70	60	120	75	150	4000	1,5	3	10,5	1,60
1	15 – 36	30 – 72	95	190	160	320	200	400	3000	1,8	5,5	25,0	2,70
2	30 – 75	60 – 150	190	380	325	650	405	810	2500	2,0	9,5	25,0	4,90
3	60 – 150	120 – 300	265	530	450	900	560	1120	2000	2,2	9,5	25,0	7,10

Size	Shaft misalignments flexible coupling							Mass moments of inertia $I$		Bores		Min. shaft length $g_4$ mm
	axial	radial			angular misalignments			Hub side $kgm^2$	Flexible side $kgm^2$	Flexible side $\varnothing d_3$ 1) mm	EAS <sup>®</sup> -NC-side $\varnothing d$ 2) mm	
	92/98 Shore A 64 Shore D $\Delta K_a$ mm	92 Shore A $\Delta K_r$ mm	98 Shore A $\Delta K_r$ mm	64 Shore D $\Delta K_r$ mm	92 Shore A $\alpha$ °	98 Shore A $\alpha$ °	64 Shore D $\alpha$ °					
01	1,2	0,10	0,06	0,04	1,0	0,9	0,8	0,00018	0,0001	10 – 20	9 – 16	18
0	1,4	0,14	0,10	0,07	1,0	0,9	0,8	0,00046	0,0004	15 – 28	12 – 20	23
1	1,5	0,15	0,11	0,08	1,0	0,9	0,8	0,00117	0,0010	19 – 35	15 – 25	27
2	1,8	0,17	0,12	0,09	1,0	0,9	0,8	0,00265	0,0020	20 – 45	22 – 35	29
3	2,0	0,19	0,14	0,1	1,0	0,9	0,8	0,00602	0,0050	28 – 45	32 – 45	32

- 1) The transmittable torques of the flexible coupling "T<sub>KN</sub>" depend on factors, as for example with temperatures, torsional stiffness etc. Please also see clutch design ROBA<sup>®</sup>-ES cat. K.940, or contact our company.  
Furthermore, the transmittable torques of the flexible coupling depend on the bore diameter  $d_3$ , please also see Table 1 on page 32  
2) shaft fit: up to  $\varnothing 38 h_8$ , above  $\varnothing 38 h_7$

## Dimensions

Size	A 4)	C <sub>6</sub>	D	D <sub>1</sub>	D <sub>H</sub>	F	F <sub>1</sub>	F <sub>2</sub>	f	f <sub>2</sub>	f <sub>4</sub>	k	k <sub>1</sub>	I <sub>1</sub>	L <sub>2</sub> 6)	L <sub>10</sub> 6)	M <sub>1</sub>	N	o 4)	p	t <sub>1</sub>	SW
01	9,5	38	–	65	40	57	–	65	35	5	46	1,0 5)	2,8	25	41	89	M6	–	– 7)	– 7)	12	7
0	10,2	47	–	80	55	63	75	80	39	5	50	1,3	2,8	30	49	103	M6	–	14,9	7,5	14	7
1	10,9	55	–	95	65	82	90	95	48	6	67	3,0	3,5	35	56	119	M8	–	17,4	7,5	13,5	8
2	12,6	61	–	106	80	103	105	110	61	6	84	5,5	4	45	62	140	M8	–	19,7	8	20	10
3	14,7	69	75	130	95	118,5	125	130	74	7	104	5,5	4	50	70	156	M8	28	23,5	9	20	10

- 4) the dimensions A; C<sub>6</sub>; o refer to the hub edge  
5) countersunk screw with hexagon socket DIN 7991  
6) dimensions in an un-tightened condition (in tightened condition shorter)  
7) thrust washer without keyway, limit switch is located at the control element-front face

We reserve the right to make dimensional and design alterations.

## Order example:

To be included when ordering, please state:	Size	Type	Bore $\varnothing d$ H <sup>7</sup>	Bore $\varnothing d_3$ F <sup>7</sup>	With limit switch
Order number:		454._0._.			see pages 36–38

- 01 – 3 →  
\* medium torque range..... 5 →  
\* high torque range..... 6 →  
\* see technical data, limiting torque for overload  $M_G$
- according to size  
→ according to size  
→ 3 flexible coupling 92 Shore A  
→ 4 flexible coupling 98 Shore A  
→ 6 flexible coupling 64 Shore D  
→ 0 ratchetting clutch  
→ 5 synchronous clutch

Example: Order number 2 / 454.605.3 / 22 / 25 with limit switch 055.002.5

**EAS<sup>®</sup>-NC with flexible backlash-free shaft coupling**  
NC-side cone bushing  
lastic-side shrink disc

Type 454.\_1.\_

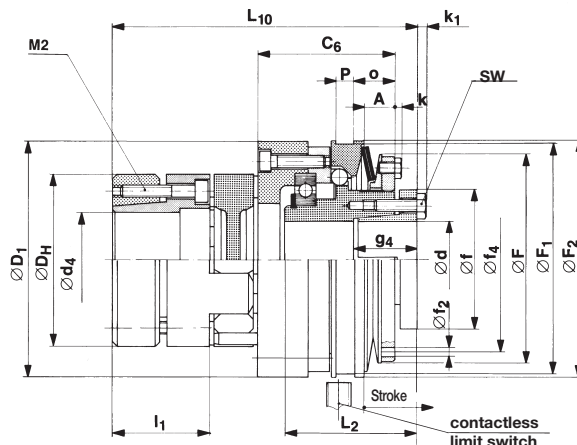

Sizes 01 – 3 Type 454.\_1.\_

## Technical data

Size	Limiting torque for overload $M_G$			Nominal torque flexible backlash-free shaft coupling $T_{KN}$ <sup>1)</sup>						Max. speed $n_{max}$ rpm	Stroke of the thrust washer in the event of an overload mm	Tightening torques clamping bolts $T_A$ at the diameter:		Weight kg
	Type	Type	Type	92 Shore A		98 Shore A		64 Shore D				$\varnothing d$ Nm	$\varnothing d_4$ Nm	
	454.51._	454.61._	454.71._	$T_{KN}$ Nm	$T_{KN max}$ Nm	$T_{KN}$ Nm	$T_{KN max}$ Nm	$T_{KN}$ Nm	$T_{KN max}$ Nm					
01	4 – 10	8 – 20	–	10	20	17	34	21	42	4000	1,2	3	3,0	0,95
0	8 – 20	15 – 40	23 – 60	35	70	60	120	75	150	4000	1,5	3	6,0	1,60
1	15 – 36	30 – 72	45 – 108	95	190	160	320	200	400	3000	1,8	5,5	6,0	2,70
2	30 – 75	60 – 150	90 – 225	190	380	325	650	405	810	2500	2,0	9,5	10,5	4,90
3	60 – 150	120 – 300	180 – 450	265	530	450	900	560	1120	2000	2,2	9,5	35,0	7,10

Size	Shaft misalignments flexible coupling							Mass moments of inertia $I$		Bores		Min. shaft length $g_4$ mm
	axial		radial		angular misalignments			Hub side kgm <sup>2</sup>	Flexible side kgm <sup>2</sup>	Flexible side $\varnothing d_4$ mm	EAS <sup>®</sup> -NC side $\varnothing d$ <sup>2)</sup> mm	
	92/98 Shore A $\Delta K_a$ mm	64 Shore D $\Delta K_r$ mm	92 Shore A $\Delta K_r$ mm	98 Shore A $\Delta K_r$ mm	64 Shore D $\Delta K_r$ mm	92 Shore A $\alpha$ °	98 Shore A $\alpha$ °					
01	1,2	0,10	0,06	0,04	1,0	0,9	0,8	0,00018	0,0001	10 – 20	9 – 16	18
0	1,4	0,14	0,10	0,07	1,0	0,9	0,8	0,00046	0,0004	15 – 25	12 – 20	23
1	1,5	0,15	0,11	0,08	1,0	0,9	0,8	0,00117	0,0010	19 – 35	15 – 25	27
2	1,8	0,17	0,12	0,09	1,0	0,9	0,8	0,00265	0,0020	20 – 40	22 – 35	29
3	2,0	0,19	0,14	0,1	1,0	0,9	0,8	0,00602	0,0050	28 – 42	32 – 45	32

- 1) The transmittable torques of the flexible coupling "T<sub>KN</sub>" depend on factors, as for example with temperatures, torsional stiffness etc. Please also see clutch design ROBA<sup>®</sup>-ES cat. K.940. or contact our company.  
2) shaft fit: up to  $\varnothing 38 h_6$ , above  $\varnothing 38 h_8$

## Dimensions

Size	A <sup>4)</sup>	C <sub>6</sub>	D <sub>1</sub>	D <sub>H</sub>	F	F <sub>1</sub>	F <sub>2</sub>	f	f <sub>2</sub>	f <sub>4</sub>	k	k <sub>1</sub>	l <sub>1</sub>	L <sub>2</sub> <sup>6)</sup>	L <sub>10</sub> <sup>6)</sup>	M <sub>2</sub>	o <sup>4)</sup>	p	SW
01	9,5	38	65	40	57	–	65	35	5	46	1,0 <sup>5)</sup>	2,8	25	41	89	6xM4	– <sup>7)</sup>	– <sup>7)</sup>	7
0	10,2	47	80	55	63	75	80	39	5	50	1,3	2,8	30	49	103	4xM5	14,9	7,5	7
1	10,9	55	95	65	82	90	95	48	6	67	3,0	3,5	35	56	119	8xM5	17,4	7,5	8
2	12,6	61	106	80	103	105	110	61	6	84	5,5	4	45	62	140	8xM6	19,7	8	10
3	14,7	69	130	95	118,5	125	130	74	7	104	5,5	4	50	70	156	4xM8	23,5	9	10

- 4) the dimensions A; C<sub>6</sub>; o refer to the hub edge  
5) countersunk screw with hexagon socket DIN 7991  
6) dimensions in an un-tightened condition (in tightened condition shorter)  
7) thrust washer without keyway, limit switch is located at the control element-front face

We reserve the right to make dimensional and design alterations.

## Order example:

To be included when ordering, please state:	Size	Type	Bore $\varnothing d$ <sup>H7</sup>	Bore $\varnothing d_4$ <sup>H7</sup>	With limit switch
Order number:		<b>454._1._</b>			see pages 36–38

- 01 – 3 → according to size  
\* medium torque range ..... 5 → according to size  
\* high torque range ..... 6 → 3 flexible coupling 92 Shore A  
\* max. torque range ..... 7 → 4 flexible coupling 98 Shore A  
6 flexible coupling 64 Shore D  
0 ratchetting clutch  
5 synchronous clutch

**Example:** Order number 2 / 454.615.3 / 22/ 25 with limit switch 055.002.5



# EAS<sup>®</sup>-NC ratchetting clutch/synchronous clutch

EAS<sup>®</sup>-NC with flexible backlash-free shaft coupling  
NC-side keyway  
lastic-side keyway

Type 454..2..

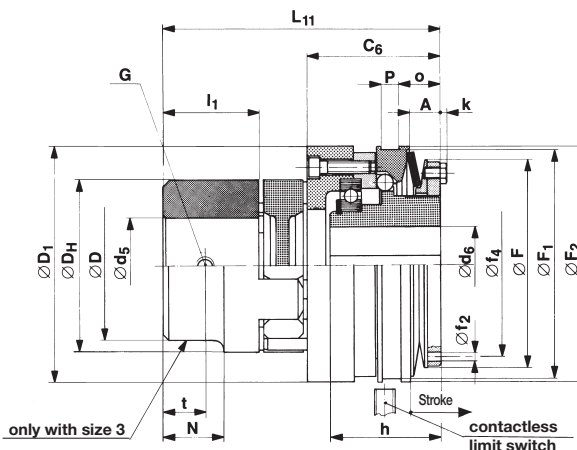

Sizes 01 – 3 Type 454..2..

## Technical data

Size	Limiting torque for overload $M_G$			Nominal torque flexible backlash-free shaft coupling $T_{KN}$ <sup>1)</sup>						Max. speed $n_{max}$ rpm	Stroke of the thrust washer in the event of an overload mm	Weight kg
	Type 454.52..	Type 454.62..	Type 454.72..	92 Shore A		98 Shore A		64 Shore D				
	Nm	Nm	Nm	$T_{KN}$ Nm	$T_{KN max}$ Nm	$T_{KN}$ Nm	$T_{KN max}$ Nm	$T_{KN}$ Nm	$T_{KN max}$ Nm			
01	4 – 10	8 – 20	–	10	20	17	34	21	42	4000	1,2	0,95
0	8 – 20	15 – 40	23 – 60	35	70	60	120	75	150	4000	1,5	1,60
1	15 – 36	30 – 72	45 – 108	95	190	160	320	200	400	3000	1,8	2,70
2	30 – 75	60 – 150	90 – 225	190	380	325	650	405	810	2500	2,0	4,90
3	60 – 150	120 – 300	180 – 450	265	530	450	900	560	1120	2000	2,2	7,10

Size	Shaft misalignments flexible coupling				angular misalignments			Mass moments of inertia I		Bores	
	axial 92/98 Shore A 64 Shore D	radial 92 Shore A	radial 98 Shore A	radial 64 Shore D	92 Shore A	98 Shore A	64 Shore D	Hub side	Flexible side	Flexible side	EAS <sup>®</sup> -NC side
	$\Delta K_a$ mm	$\Delta K_r$ mm	$\Delta K_r$ mm	$\Delta K_r$ mm	$\alpha$ °	$\alpha$ °	$\alpha$ °	kgm <sup>2</sup>	kgm <sup>2</sup>	$\varnothing d_5$ mm	$\varnothing d$ mm
01	1,2	0,10	0,06	0,04	1,0	0,9	0,8	0,00018	0,0001	6 – 24	9 – 20
0	1,4	0,14	0,10	0,07	1,0	0,9	0,8	0,00046	0,0004	8 – 28	12 – 20
1	1,5	0,15	0,11	0,08	1,0	0,9	0,8	0,00117	0,0010	10 – 38	15 – 25
2	1,8	0,17	0,12	0,09	1,0	0,9	0,8	0,00265	0,0020	12 – 45	22 – 35 <sup>3)</sup>
3	2,0	0,19	0,14	0,1	1,0	0,9	0,8	0,00602	0,0050	14 – 55	32 – 45

1) The transmittable torques of the flexible coupling "T<sub>KN</sub>" depend on factors, as for example with temperatures, torsional stiffness etc.

Please also see clutch design ROBA<sup>®</sup>-ES cat. K.940. or contact our company.

2) shaft fit: up to  $\varnothing 38 h_6$ , above  $\varnothing 38 h_8$

3) up to  $\varnothing 33$  keyway to DIN 6885/1, above  $\varnothing 33$  keyway to DIN 6885/3

## Dimensions

Size	A <sup>4)</sup>	C <sub>6</sub>	D	D <sub>1</sub>	D <sub>H</sub>	F	F <sub>1</sub>	F <sub>2</sub>	f <sub>2</sub>	f <sub>4</sub>	G	h	k	l <sub>1</sub>	L <sub>11</sub>	N	o <sup>4)</sup>	p	t
01	9,5	38	–	65	40	57	–	65	5	46	M5	33	1,0 <sup>5)</sup>	25	80	–	– <sup>7)</sup>	– <sup>7)</sup>	10
0	10,2	47	–	80	55	63	75	80	5	50	M5	41	1,3	30	95	–	14,9	7,5	10
1	10,9	55	–	95	65	82	90	95	6	67	M6	47	3,0	35	110	–	17,4	7,5	15
2	12,6	61	–	106	80	103	105	110	6	84	M8	52	5,5	45	130	–	19,7	8	15
3	14,7	69	75	130	95	118,5	125	130	7	104	M8	59	5,5	50	145	28	23,5	9	20

4) the dimensions A; C<sub>6</sub>; o refer to the hub edge

5) countersunk screw with hexagon socket DIN 7991

7) thrust washer without keyway, limit switch is located at the control element-front face

We reserve the right to make dimensional and design alterations.

## Order example:

To be included when ordering, please state:	Size	Type	Bore $\varnothing d_6^{H7}$	Bore $\varnothing d_5^{H7}$	With limit switch
Order number:		4 5 4 . _ 2 . _ . _			see pages 36–38

01 – 3 →

\* medium torque range..... 5 →

\* high torque range..... 6 →

\* max. torque range..... 7 →

\* see technical data, limiting torque for overload  $M_G$

→ according to size  
→ according to size  
→ 3 flexible coupling 92 Shore A  
→ 4 flexible coupling 98 Shore A  
→ 6 flexible coupling 64 Shore D  
→ 0 ratchetting clutch  
→ 5 synchronous clutch

Example: Order number 2 / 454.625.3 / 22/ 25 with limit switch 055.002.5

## Short hub with fitting dimensions of the type series 400 and cone bushing

Type 451\_1\_0

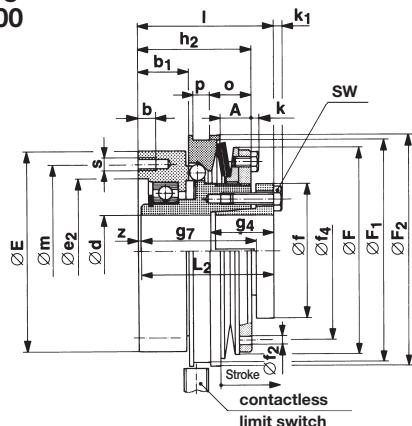

Sizes 01 – 3

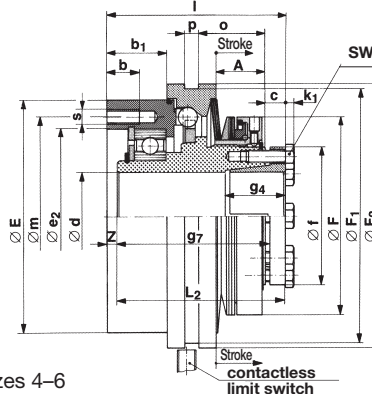

Sizes 4–6

## Technical data

1) Size	Limiting torques for overload $M_G$ 1)				Max. speed $n_{max}$ rpm	Stroke of the thrust washer in the event of an overload mm	Mass moments of inertia I		Weight kg	Clamping bolts and tightening torques for Ø d	
	Type 451.41_0 Nm	Type 451.51_0 Nm	Type 451.61_0 Nm	Type 451.71_0 Nm			Hub side kgm <sup>2</sup>	Pressure flange side kgm <sup>2</sup>		mm	Nm
01	–	4 – 10	8 – 20	12 – 30	4000	1,2	0,000191	0,000091	0,62	4 x M4	3,5
1	–	15 – 36	30 – 72	45 – 108	3000	1,8	0,001194	0,000572	1,78	6 x M5	5,5
2	–	30 – 75	60 – 150	90 – 225	2500	2,0	0,00270	0,00121	3,27	6 x M6	9,5
3	–	60 – 150	120 – 300	180 – 450	2000	2,2	0,00614	0,00280	4,34	8 x M6	9,5
4	75 – 150	150 – 300	300 – 600	–	400	2,5	0,03211	0,01548	10,3	8 x M8	20
5	150 – 300	300 – 600	600 – 1200	–	400	2,8	0,05325	0,03732	17,0	8 x M10	40
6	300 – 600	600 – 1200	1200 – 2400	–	300	3,4	0,07178	0,03783	21,0	8 x M12	60

## Dimensions

Size	Bore d 2) from – to mm	Min. shaft length		A 7)	b	b <sub>1</sub>	c	E	e <sub>2</sub> H7 6)	F	F <sub>1</sub>	F <sub>2</sub>
		g <sub>4</sub> mm	g <sub>7</sub> mm									
01	9 – 16	18	36	9,5	8	18,5	–	55	42 M7	57	– 5)	65
1	15 – 25	27	49	10,9	10	23,1	–	82	62 M7	82	90	95
2	22 – 35	29	54	12,6	10	21,8	–	100	78	103	105	110
3	32 – 45	32	61	14,7	12	24,5	–	120	90,5	118,5	125	130
4	35 – 55	38	96	31	20	37,5	13	146	110	125	160	166
5	42 – 65	51	111	36,5	25	42	16	176	130	145	185	196
6	50 – 75	60	117	38	26	44	20	186	145	165	214	220

Size	f	f <sub>2</sub>	f <sub>4</sub>	h <sub>2</sub> 7)	k	k <sub>1</sub>	L <sub>2</sub> 3)	l 3)	m	o 7)	p	s	SW	z
01	35	5	46	37	0,3 4)	2,8	41	45	48	– 5)	– 5)	6 x M5	7	4
1	48	6	67	51	3,0	3,5	56	60	70	17,4	7,5	6 x M5	8	4
2	61	6	84	54	5,3	4	62	64	89	19,7	8	6 x M6	10	2
3	74	7	104	61,5	5,3	4	70	72,5	105	23,5	9	6 x M8	10	2,5
4	87	–	–	–	–	5,5	106	112,5	125	42	9	6 x M10	13	6,5
5	110	–	–	–	–	7	123	129,5	155	48,5	9	6 x M12	17	6,5
6	124	–	–	–	–	8	132	139	160	46	9	6 x M12	19	7

- 1) other sizes for lower and higher torques on request
- 2) shaft fit: up to Ø 38 h<sub>8</sub>, above Ø 38 h<sub>7</sub>
- 3) dimensions in an un-tightened condition (in a tightend condition shorter)
- 4) countersunk screw with hexagon socket DIN 7991
- 5) thrust washer without keyway, limit switch is located at the control element-front face

We reserve the right to make dimensional and design alterations.

- 6) H7 beside of sizes 01 and 1
- 7) for sizes 01–3 the dimensions A; h<sub>2</sub>; o refer to the hub edge

## Order example:

To be included when ordering, please state:	Size	Type	Bore Ø d H7	With limit switch
Order number:		451_1_0		see pages 36–38

- 01 – 6 →
- \* low torque range ..... 4 →
- \* medium torque range ..... 5 →
- \* high torque range ..... 6 →
- \* max. torque range ..... 7 →
- according to size
- 0 ratchetting clutch
- 5 synchronous clutch

\* see technical data, limiting torque for overload  $M_G$

**Example:** Order number 6 / 451.610.0 / 60 / 6885-1 with limit switch 055.002.5

# EAS<sup>®</sup>-NC ratchetting clutch/synchronous clutch

Short hub with fitting dimensions  
of the type series 400  
and keyway

Type 451.\_2\_.0

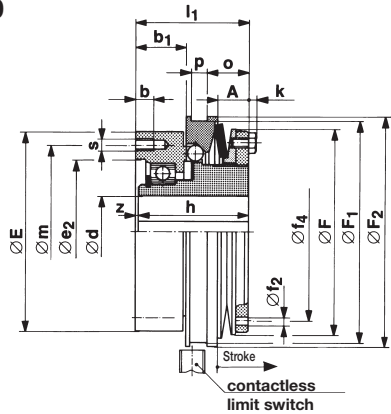

Sizes 01 – 3

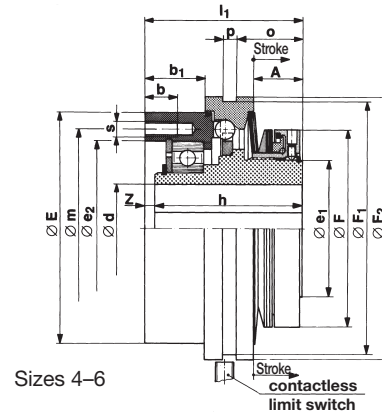

Sizes 4–6

## Technical data

1) Size	Limiting torques for overload $M_G$ <sup>1)</sup>				Max. speed $n_{max}$ rpm	Stroke of the thrust washer in the event of an overload mm	Mass moments of inertia I		Weight kg
	Type 451.42_0 Nm	Type 451.52_0 Nm	Type 451.62_0 Nm	Type 451.72_0 Nm			Hub side kgm <sup>2</sup>	Pressure flange side kgm <sup>2</sup>	
01	–	4 – 10	8 – 20	12 – 30	4000	1,2	0,000190	0,000091	0,57
1	–	15 – 36	30 – 72	45 – 108	3000	1,8	0,001191	0,000572	1,77
2	–	30 – 75	60 – 150	90 – 225	2500	2,0	0,00265	0,00121	3,10
3	–	60 – 150	120 – 300	180 – 450	2000	2,2	0,00596	0,00280	4,11
4	75 – 150	150 – 300	300 – 600	–	400	2,5	0,03173	0,01548	10,4
5	150 – 300	300 – 600	600 – 1200	–	400	2,8	0,04960	0,03732	16,9
6	300 – 600	600 – 1200	1200 – 2400	–	300	3,4	0,06921	0,03783	20,5

## Dimensions

Size	Bore		A <sup>6)</sup>	b	b <sub>1</sub>	E	e <sub>1</sub>	e <sub>2</sub> <sup>H7/5)</sup>	F	F <sub>1</sub>
	d <sub>min</sub> mm	d <sub>max</sub> mm								
01	9	20	9,5	8	18,5	55	–	42 <sup>M7</sup>	57	– <sup>3)</sup>
1	15	25	10,9	10	23,1	82	–	62 <sup>M7</sup>	82	90
2	22	35 <sup>4)</sup>	12,6	10	21,8	100	–	78	103	105
3	32	45	14,7	12	24,5	120	–	90,5	118,5	125
4	22	55	31	20	37,5	146	87	110	125	160
5	28	65	36,5	25	42	176	102,5	130	145	185
6	45	75	38	26	44	186	125	145	165	214

Size	F <sub>2</sub>	f <sub>2</sub>	f <sub>4</sub>	h	k	l <sub>1</sub> <sup>6)</sup>	m	o <sup>6)</sup>	p	s	z
01	65	5	46	33	1,0 <sup>2)</sup>	37	48	– <sup>3)</sup>	– <sup>3)</sup>	6 x M5	4
1	95	6	67	47	3,0	51	70	17,4	7,5	6 x M5	4
2	110	6	84	52	5,3	54	89	19,7	8	6 x M6	2
3	130	7	104	59	5,3	61,5	105	23,5	9	6 x M8	2,5
4	166	–	–	93	–	99,5	125	42	9	6 x M10	6,5
5	196	–	–	107	–	113,5	155	48,5	9	6 x M12	6,5
6	220	–	–	112	–	119	160	46	9	6 x M12	7

- 1) other sizes for lower and higher torques on request
- 2) countersunk screw with hexagon socket DIN 7991
- 3) thrust washer without keyway, limit switch is located at the control element-front face
- 4) up to Ø 33 keyway to DIN 6885/1, above Ø 33 keyway to DIN 6885/3
- 5) H7 beside of sizes 01 and 1

We reserve the right to make dimensional and design alterations.

- 6) for sizes 01–3 the dimensions A; l<sub>1</sub>; o refer to the hub edge
- 7) Position of the keyway to the mounting bore "s" in the pressure flange not defined. A defined position is possible on request.

## Order example:

To be included when ordering, please state:	Size	Type	Bore Ø d <sup>H7</sup>	With limit switch
Order number:		451._2_.0	7)	see pages 36–38

- 01 – 6 →
- \* low torque range ..... 4 →
- \* medium torque range ..... 5 →
- \* high torque range ..... 6 →
- \* max. torque range ..... 7 →
- \* see technical data, limiting torque for overload  $M_G$
- according to size
- 0 ratchetting clutch
- 5 synchronous clutch

**Example:** Order number 6 / 451.620.0 / 60 / 6885-1 with limit switch 055.002.5

Long projecting hub  
with cone bushing  
and fitting dimensions  
of the type series 400

Type 451\_1\_1

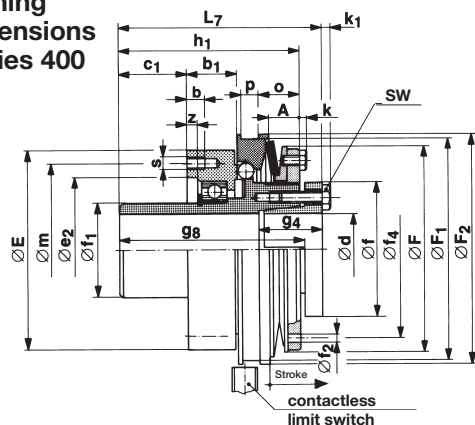

Sizes 01 – 3

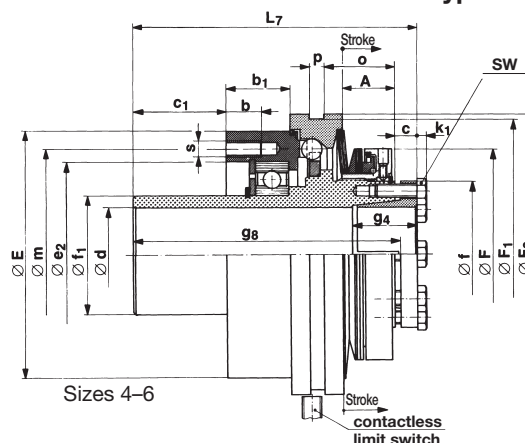

Sizes 4–6

## Technical data

1) Size	Limiting torques for overload $M_G$ 1)				Max. speed $n_{max}$ rpm	Stroke of the thrust washer in the event of an overload mm	Mass moments of inertia I		Weight kg	Clamping bolts and tightening torques for $\varnothing d$	
	Type 451.41_1 Nm	Type 451.51_1 Nm	Type 451.61_1 Nm	Type 451.71_1 Nm			Hub side mm	Pressure flange side kgm <sup>2</sup>		mm	Nm
01	–	4 – 10	8 – 20	12 – 30	4000	1,2	0,00025	0,000091	0,70	4 x M4	3,5
1	–	15 – 36	30 – 72	45 – 108	3000	1,8	0,00125	0,000572	1,93	6 x M5	5,5
2	–	30 – 75	60 – 150	90 – 225	2500	2,0	0,00284	0,00121	3,69	6 x M6	9,5
3	–	60 – 150	120 – 300	180 – 450	2000	2,2	0,00670	0,00280	5,42	8 x M6	9,5
4	75 – 150	150 – 300	300 – 600	–	400	2,5	0,03313	0,01548	11,7	8 x M8	20
5	150 – 300	300 – 600	600 – 1200	–	400	2,8	0,05325	0,03732	19,1	8 x M10	40
6	300 – 600	600 – 1200	1200 – 2400	–	300	3,4	0,07590	0,03783	24,0	8 x M12	60

## Dimensions

Size	Bore $d$ 2) from – to mm	Min. shaft length		A 7)	b	b <sub>1</sub>	c	c <sub>1</sub>	E	e <sub>2</sub> H7 6)	F	F <sub>1</sub>	F <sub>2</sub>
		g <sub>4</sub> mm	g <sub>8</sub> mm										
01	9 – 16	18	61	9,5	8	18,5	–	21	55	42 M7	57	– 5)	65
1	15 – 25	27	79	10,9	10	23,1	–	26	82	62 M7	82	90	95
2	22 – 35	29	92	12,6	10	21,8	–	36	100	78	103	105	110
3	32 – 45	32	111	14,7	12	24,5	–	47,5	120	90,5	118,5	125	130
4	35 – 55	38	155	31	20	37,5	13	52,5	146	110	125	160	166
5	42 – 65	51	175	36,5	25	42	16	57,5	176	130	145	185	196
6	50 – 75	60	188	38	26	44	20	64	186	145	165	214	220

Size	f	f <sub>1</sub> h6	f <sub>2</sub>	f <sub>4</sub>	h <sub>1</sub> 7)	k	k <sub>1</sub>	L <sub>7</sub> 3)	m	o 7)	p	s	SW	z
01	35	30	5	46	58	1,0 4)	2,8	66	48	– 5)	– 5)	6 x M5	7	5,5
1	48	40	6	67	77	3,0	3,5	86	70	17,4	7,5	6 x M5	8	7,25
2	61	50	6	84	90	5,3	4	100	89	19,7	8	6 x M6	10	5
3	74	65	7	104	109	5,3	4	120	105	23,5	9	6 x M8	10	5
4	87	70	–	–	–	–	5,5	165	125	42	9	6 x M10	13	–
5	110	85	–	–	–	–	7	187	155	48,5	9	6 x M12	17	–
6	124	95	–	–	–	–	8	203	160	46	9	6 x M12	19	–

- 1) other sizes for lower and higher torques on request
- 2) shaft fit: up to  $\varnothing 38$  h<sub>6</sub>, above  $\varnothing 38$  h<sub>8</sub>
- 3) dimensions in an un-tightened condition (in tightened condition shorter)
- 4) countersunk screw with hexagon socket DIN 7991
- 5) thrust washer without keyway, limit switch is located at the control element-front face

We reserve the right to make dimensional and design alterations.

- 6) H7 beside of sizes 01 and 1
- 7) for sizes 01–3 the dimensions A; h<sub>1</sub>; o refer to the hub edge

## Order example:

To be included when ordering, please state:	Size	Type	Bore $\varnothing d$ H7	With limit switch
Order number:		<b>451_1_1</b>		see pages 36–38

- 01 – 6 →
- \* low torque range ..... 4 →
  - \* medium torque range ..... 5 →
  - \* high torque range ..... 6 →
  - \* max. torque range ..... 7 →
- according to size  
→ 0 ratchetting clutch  
→ 5 synchronous clutch

\* see technical data, limiting torque for overload  $M_G$

**Example:** Order number 4 / 451.610.1 / 40 with limit switch 055.002.5



# EAS<sup>®</sup>-NC ratchetting clutch/synchronous clutch

Long projecting hub with keyway  
and fitting dimensions  
of the type series 400

Type 451.\_2\_.1

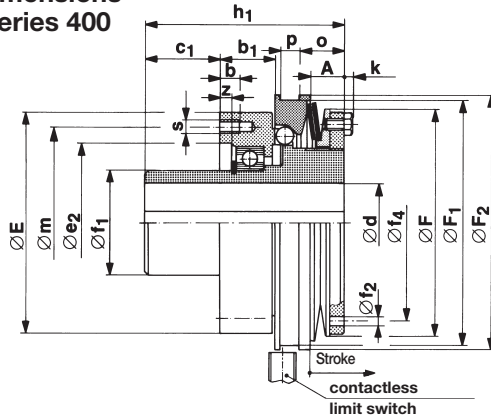

Sizes 01 – 3

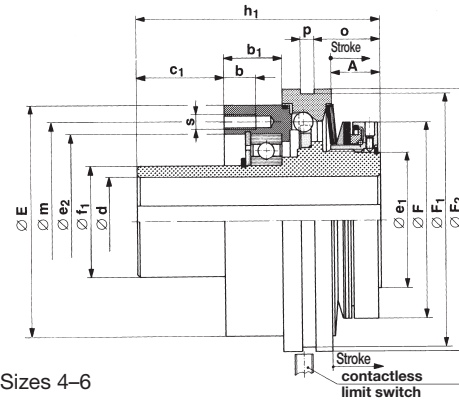

Sizes 4–6

## Technical data

1) Size	Limiting torques for overload $M_G$ 1)				Max. speed $n_{max}$ rpm	Stroke of the thrust washer in the event of an overload mm	Mass moments of inertia I		Weight kg
	Type 451.42_.1 Nm	Type 451.52_.1 Nm	Type 451.62_.1 Nm	Type 451.72_.1 Nm			Hub side kgm <sup>2</sup>	Pressure flange side kgm <sup>2</sup>	
01	–	4 – 10	8 – 20	12 – 30	4000	1,2	0,00025	0,000091	0,65
1	–	15 – 36	30 – 72	45 – 108	3000	1,8	0,00125	0,000572	1,92
2	–	30 – 75	60 – 150	90 – 225	2500	2,0	0,00279	0,00121	3,52
3	–	60 – 150	120 – 300	180 – 450	2000	2,2	0,00652	0,00280	5,19
4	75 – 150	150 – 300	300 – 600	–	400	2,5	0,03224	0,01548	12,0
5	150 – 300	300 – 600	600 – 1200	–	400	2,8	0,05215	0,03732	19,5
6	300 – 600	600 – 1200	1200 – 2400	–	300	3,4	0,07353	0,03783	23,8

## Dimensions

Size	Bore		A 6)	b	b <sub>1</sub>	c <sub>1</sub>	E	e <sub>1</sub>	H7 5) e <sub>2</sub>	F
	d <sub>min</sub> mm	d <sub>max</sub> mm								
01	9	20	9,5	8	18,5	21	55	–	42 M7	57
1	15	25	10,9	10	23,1	26	82	–	62 M7	82
2	22	35 4)	12,6	10	21,8	36	100	–	78	103
3	32	45	14,7	12	24,5	47,5	120	–	90,5	118,5
4	22	55	31	20	37,5	52,5	146	87	110	125
5	28	65	36,5	25	42	57,5	176	102,5	130	145
6	45	75	38	26	44	64	186	125	145	165

Size	F <sub>1</sub>	F <sub>2</sub>	f <sub>1</sub> h6	f <sub>2</sub>	f <sub>4</sub>	h <sub>1</sub> 6)	k	m	o 6)	p	s	z
01	– 3)	65	30	5	46	58	1,0 2)	48	– 3)	– 3)	6 x M5	5,5
1	90	95	40	6	67	77	3,0	70	17,4	7,5	6 x M5	7,25
2	105	110	50	6	84	90	5,3	89	19,7	8	6 x M6	5
3	125	130	65	7	104	109	5,3	105	23,5	9	6 x M8	5
4	160	166	70	–	–	152	–	125	42	9	6 x M10	–
5	185	196	85	–	–	171	–	155	48,5	9	6 x M12	–
6	214	220	95	–	–	183	–	160	46	9	6 x M12	–

- 1) other sizes for lower and higher torques on request
- 2) countersunk screw with hexagon socket DIN 7991
- 3) thrust washer without keyway, limit switch is located at the control element-front face
- 4) up to Ø 33 keyway to DIN 6885/1, above Ø 33 keyway to DIN 6885/3

We reserve the right to make dimensional and design alterations.

- 5) H7 beside of sizes 01 and 1
- 6) for sizes 01–3 the dimensions A; h<sub>1</sub>; o refer to the hub edge
- 7) Position of the keyway to the mounting bore "s" in the pressure flange not defined. A defined position is possible on request.

## Order example:

To be included when ordering, please state:	Size	Type	Bore Ø d H7	With limit switch
Order number:		451._2_.1	7)	see pages 36–38

- 01 – 6 →
- \* low torque range ..... 4 →
  - \* medium torque range ..... 5 →
  - \* high torque range ..... 6 →
  - \* max. torque range ..... 7 →
- \* see technical data, limiting torque for overload  $M_G$
- according to size  
→ 0 ratchetting clutch  
→ 5 synchronous clutch

**Example:** Order number 6 / 451.520.1 / 60 / 6885-1 with limit switch 055.002.5

Short supported hub with cone bushing  
and fitting dimensions of  
the type series 400

Type 451.\_1\_.5

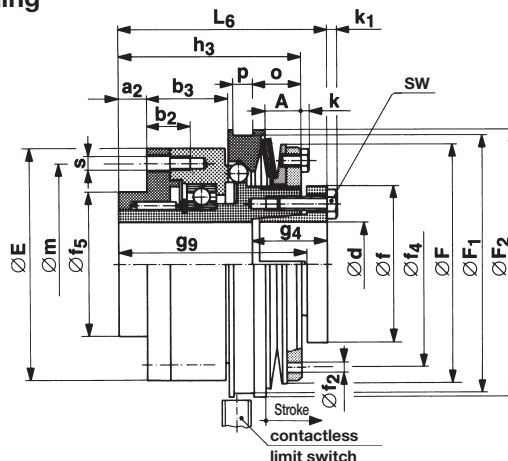

Sizes 01 – 3 Type 451.\_1\_.5

## Technical data

1) Size	Limiting torques for overload $M_G$ 1)			Max. speed $n_{max}$ rpm	Stroke of the thrust washer in the event of an overload mm	Mass moments of inertia I		Weight kg	Clamping bolts and tightening torques for Ø d	
	Type 451.51_.5 Nm	Type 451.61_.5 Nm	Type 451.71_.5 Nm			Hub side kgm <sup>2</sup>	Pressure flange side kgm <sup>2</sup>		mm	Nm
01	4 – 10	8 – 20	12 – 30	4000	1,2	0,000201	0,000121	0,82	4 x M4	3,5
1	15 – 36	30 – 72	45 – 108	3000	1,8	0,001224	0,000862	2,28	6 x M5	5,5
2	30 – 75	60 – 150	90 – 225	2500	2,0	0,00285	0,00154	3,57	6 x M6	9,5
3	60 – 150	120 – 300	180 – 450	2000	2,2	0,00638	0,00384	5,64	8 x M6	9,5

## Dimensions

Size	Bore d 2) from-to mm	Min. shaft length		A 6)	a <sub>2</sub>	b <sub>2</sub>	b <sub>3</sub>	E	F	F <sub>1</sub>	F <sub>2</sub>
		g <sub>4</sub> mm	g <sub>9</sub> mm								
01	9 – 16	18	52,5	9,5	8	12,5	23	55	57	– 5)	65
1	15 – 25	27	71	10,9	10	18	31,1	82	82	90	95
2	22 – 35	29	73	12,6	12	15	26,8	100	103	105	110
3	32 – 45	32	81,5	14,7	12	18	30,5	120	118,5	125	130

Size	f	f <sub>2</sub>	f <sub>4</sub>	f <sub>5</sub> h <sub>6</sub>	h <sub>3</sub> 6)	k	k <sub>1</sub>	L <sub>6</sub> 3)	m	o 6)	p	s	SW
01	35	5	46	38	49,5	1,0 4)	2,8	57,5	48	– 5)	– 5)	6 x M5	7
1	48	6	67	50	69	3,0	3,5	78	70	17,4	7,5	6 x M5	8
2	61	6	84	60	71	5,3	4	81	89	19,7	8	6 x M6	10
3	74	7	104	80	79,5	5,3	4	90,5	105	23,5	9	6 x M8	10

- 1) other sizes for lower and higher torques on request
- 2) shaft fit: up to Ø 38 h<sub>6</sub>, above Ø 38 h<sub>8</sub>
- 3) dimensions in an un-tightened condition (in tightened condition shorter)
- 4) countersunk screw with hexagon socket DIN 7991
- 5) thrust washer without keyway, limit switch is located at the control element-front face
- 6) the dimensions A; h<sub>3</sub>; o refer to the hub edge

We reserve the right to make dimensional and design alterations.

## Order example:

To be included when ordering, please state:	Size	Type	Bore Ø d H7	With limit switch
Order number:		451._1_.5		see pages 36–38

- 01 – 3 → according to size
- \* medium torque range. . . . . 5 → 0 ratchetting clutch
- \* high torque range. . . . . 6 → 5 synchronous clutch
- \* max. torque range . . . . . 7 →
- \* see technical data, limiting torque for overload  $M_G$

**Example:** Order number 2 / 451.510.5 / 30 with limit switch 055.002.5

# EAS<sup>®</sup>-NC ratchetting clutch/synchronous clutch

Short supported hub with keyway  
and fitting dimensions of  
the type series 400

Type 451.\_2\_.5

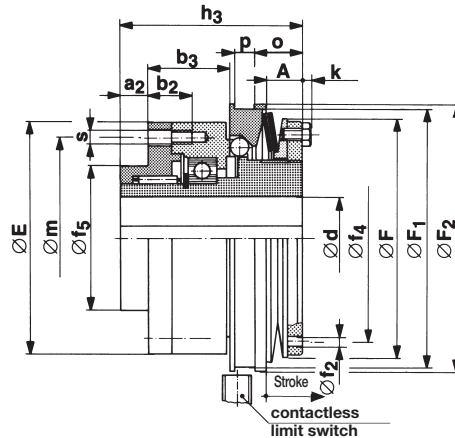

Sizes 01 – 3 Type 451.\_2\_.5

## Technical data

1) Size	Limiting torques for overload $M_G$ 1)			Max. speed $n_{max}$ rpm	Stroke of the thrust washer in the event of an overload mm	Mass moments of inertia I		Weight kg
	Type 451.52_.5 Nm	Type 451.62_.5 Nm	Type 451.72_.5 Nm			Hub side kgm <sup>2</sup>	Pressure flange side kgm <sup>2</sup>	
01	4 – 10	8 – 20	12 – 30	4000	1,2	0,000200	0,000121	0,77
1	15 – 36	30 – 72	45 – 108	3000	1,8	0,001221	0,000862	2,77
2	30 – 75	60 – 150	90 – 225	2500	2,0	0,00280	0,00154	3,40
3	60 – 150	120 – 300	180 – 450	2000	2,2	0,00620	0,00384	5,41

## Dimensions

Size	Bore		A 5)	a <sub>2</sub>	b <sub>2</sub>	b <sub>3</sub>	E	F	F <sub>1</sub>	F <sub>2</sub>
	d <sub>min</sub> mm	d <sub>max</sub> mm								
01	9	20	9,5	8	12,5	23	55	57	-- 4)	65
1	15	25	10,9	10	18	31,1	82	82	90	95
2	22	35 3)	12,6	12	15	26,8	100	103	105	110
3	32	45	14,7	12	18	30,5	120	118,5	125	130

Size	f <sub>2</sub>	f <sub>4</sub>	f <sub>5</sub> h <sub>6</sub>	h <sub>3</sub> 5)	k	m	o 5)	p	s
01	5	46	38	49,5	1,0 2)	48	-- 4)	-- 4)	6 x M5
1	6	67	50	69	3,0	70	17,4	7,5	6 x M6
2	6	84	60	71	5,3	89	19,7	8	6 x M6
3	7	104	80	79,5	5,3	105	23,5	9	6 x M8

- 1) other sizes for lower and higher torques on request
- 2) countersunk screw with hexagon socket DIN 7991
- 3) up to Ø 33 keyway to DIN 6885/1, above Ø 33 keyway to DIN 6885/3
- 4) thrust washer without keyway, limit switch is located at the control element-front face
- 5) the dimensions A; h<sub>3</sub>; o refer to the hub edge
- 6) Position of the keyway to the mounting bore "s" in the pressure flange not defined.  
A defined position is possible on request.

We reserve the right to make dimensional and design alterations.

## Order example:

To be included when ordering, please state:	Size	Type	Bore Ø d <sup>H7</sup>	With limit switch
Order number:		451._2_.5	6)	see pages 36–38

- 01 – 3 → according to size  
 \* medium torque range. . . . . 5 → 0 ratchetting clutch  
 \* high torque range. . . . . 6 → 5 synchronous clutch  
 \* max. torque range . . . . . 7 →
- \* see technical data, limiting torque for overload  $M_G$

**Example:** Order number 2 / 451.520.5 / 30 / 6885-1 with limit switch 055.002.5

Torsionally rigid with cone bushing

Type 456.\_1\_.8

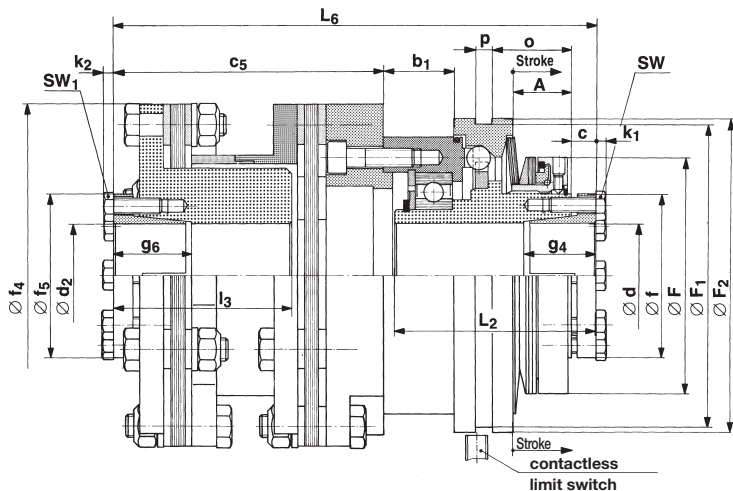

Sizes 4 – 6      Type 456.\_1\_.8

### Technical data

1) Size	Limiting torques for overload $M_G$ 1)			Nominal torque of flexible torsionally rigid coupling $T_{KN}$ Nm	Max. speed $n_{max}$ rpm	Stroke of the thrust washer in the event of an overload mm	Permissible flexibility		
	Type 456.41_.8 Nm	Type 456.51_.8 Nm	Type 456.61_.8 Nm				axial $\Delta K_a$ mm	angular $\Delta K_w$ °	radial $\Delta K_r$ mm
4	75 – 150	150 – 300	300 – 600	1000	400	2,5	1,6	2	2,2
5	150 – 300	300 – 600	600 – 1200	1600	400	2,8	1,8	2	2,2
6	300 – 600	600 – 1200	1200 – 2400	2500	300	3,4	1,8	2	2,5

Size	Mass moments of inertia I		Weight kg	Clamping bolts and tightening torques				Bore 2)		Min. shaft length	
	Hub side kgm <sup>2</sup>	Flexible side kgm <sup>2</sup>		at $\varnothing d$		at $\varnothing d_2$		d from – to mm	$d_2$ from – to mm	$g_4$ mm	$g_6$ mm
4	0,03211	0,07278	25,8	8 x M8	20	8 x M10	30	35 – 55	42 – 65	38	51
5	0,05083	0,16973	39,6	8 x M10	40	8 x M12	40	42 – 65	50 – 75	51	60
6	0,07179	0,17255	46,5	8 x M12	60	8 x M12	60	50 – 75	55 – 85	60	60

### Dimensions

Size	A	$b_1$	c	$c_5$ 3)	F	$F_1$	$F_2$	f	$f_4$	$f_5$
4	31	37,5	13	198	125	160	166	87	180	110
5	36,5	42	16	208	145	185	196	110	200	124
6	38	44	20	228	165	214	220	124	215	135

Size	$k_1$	$k_2$	$L_2$ 3)	$L_6$ 3)	$l_3$ 3)	o	p	SW	$SW_1$
4	5,5	7	106	310,5	96	42	9	13	17
5	7	8	123	337,5	100	48,5	9	17	19
6	8	9	132	367	110	46	9	19	19

1) other sizes for lower and higher torques on request  
 2) shaft fit: up to  $\varnothing 38_{H6}$ , above  $\varnothing 38_{H8}$   
 3) dimensions in an un-tightened condition (in a tightened condition shorter)

We reserve the right to make dimensional and design alterations.

### Order example:

To be included when ordering, please state:	Size	Type	Bore $\varnothing d_{H7}$	Bore $\varnothing d_2_{H7}$	With limit switch
Order number:		<b>4 5 6 . _ 1 . 8</b>			see pages 36 – 38

4 – 6 → according to size  
 \* low torque range ..... 4 → according to size  
 \* medium torque range ..... 5 → 0 ratchetting clutch  
 \* high torque range ..... 6 → 5 synchronous clutch  
 \* see technical data, limiting torque for overload  $M_G$

**Example:** Order number 6 / 456.510.8 / 50 / 60 plus limit switch 055.002.5



# EAS<sup>®</sup>-NC ratchetting clutch/synchronous clutch

Torsionally rigid with keyway

Type 456.\_2\_.8

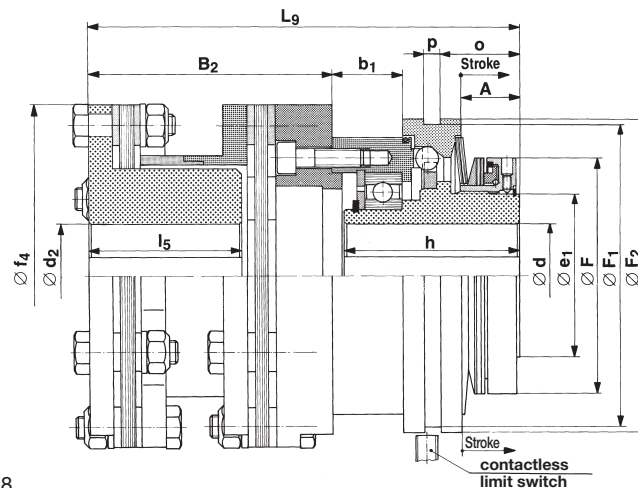

Sizes 4 – 6 Type 456.\_2\_.8

## Technical data

1) Size	Limiting torques for overload $M_G$ 1)			Nominal torque of flexible torsionally rigid coupling $T_{KN}$ Nm	Max. speed $n_{max}$ rpm	Stroke of the thrust washer in the event of an overload mm	Permissible flexibility		
	Type 456.42_.8 Nm	Type 456.52_.8 Nm	Type 456.62_.8 Nm				axial $\Delta K_a$ mm	angular $\Delta K_w$ °	radial $\Delta K_r$ Sleeve 1 mm
4	75 – 150	150 – 300	300 – 600	1000	400	2,5	1,6	2	2,2
5	150 – 300	300 – 600	600 – 1200	1600	400	2,8	1,8	2	2,2
6	300 – 600	600 – 1200	1200 – 2400	2500	300	3,4	1,8	2	2,5

Size	Mass moments of inertia I		Weight kg	Bore			
	Hub side $kgm^2$	Flexible side $kgm^2$		$d_{min}$ mm	$d_{max}$ mm	$d_2$ min mm	$d_2$ max mm
4	0,03173	0,07151	25,8	22	55	28	80
5	0,04960	0,11552	35,2	28	65	30	85
6	0,06921	0,14818	45,4	45	75	38	90

## Dimensions

Size	A	B <sub>2</sub>	b <sub>1</sub>	e <sub>1</sub>	F	F <sub>1</sub>
4	31	182	37,5	87	125	160
5	36,5	188	42	102,5	145	185
6	38	208	44	125	165	214

Size	F <sub>2</sub>	f <sub>4</sub>	h	L <sub>9</sub>	l <sub>5</sub>	o	p
4	166	180	93	281,5	80	42	9
5	196	200	107	301,5	80	48,5	9
6	220	215	112	327	90	46	9

1) other sizes for lower and higher torques on request

We reserve the right to make dimensional and design alterations.

## Order example:

To be included when ordering, please state:	Size	Type	Bore $\varnothing d^{H7}$	Bore $\varnothing d_2^{H7}$	With limit switch
Order number:		4 5 6 . _ 2 . _ 8			see pages 36 – 38

4 – 6 →  
 \* low torque range ..... 4 →  
 \* medium torque range. .... 5 →  
 \* high torque range ..... 6 →  
 \* see technical data, limiting torque for overload  $M_G$

→ according to size  
 → according to size  
 → 0 ratchetting clutch  
 → 5 synchronous clutch

**Example:** Order number 4 / 456.520.8 / 50 / 6885-1 / 60 / 6885-1 with limit switch 055.002.5

Lastic with  
Keyway EAS<sup>®</sup>-side  
keyway lastic-side

Type 457.\_2\_.0

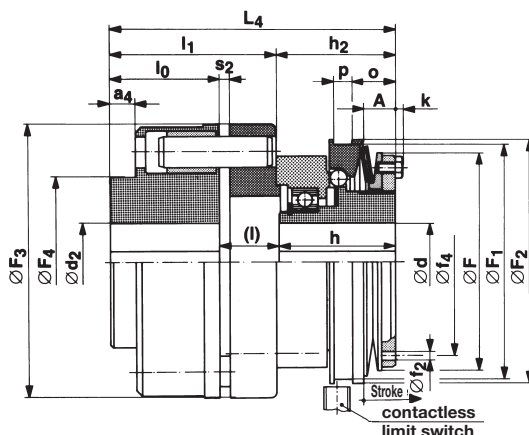

Sizes 01 – 3 Type 457.\_2\_.0

## Technical data

1) Size	Limiting torques for overload $M_G$ 1)		Nominal torque of flexible torsionally rigid coupling $T_{KN}$ Nm	Max. speed $n_{max}$ rpm	Stroke of the thrust washer in the event of an overload mm	Permissible flexibility		
	Type 457.52_.0 Nm	Type 457.62_.0 Nm				axial $\Delta K_a$ mm	angular $\Delta K_w$ °	radial $\Delta K_r$ mm
01	4 – 10	8 – 20	75	4000	1,2	±1	0,5	0,5
1	15 – 36	30 – 72	150	3000	1,8	±1	0,5	0,5
2	30 – 75	60 – 150	150	2500	2,0	±1	0,5	0,5
3	60 – 150	120 – 300	300	2000	2,2	±1	0,5	0,5

Size	Mass moments of inertia $I$		Weight kg	Bore d from – to mm	Bore	
	Hub side kgm <sup>2</sup>	Flexible Side kgm <sup>2</sup>			$d_{2\ min}$ mm	$d_{2\ max}$ mm
01	0,000190	0,000811	1,57	9 – 20	11	30
1	0,001191	0,00365	4,1	15 – 25	11	42
2	0,00265	0,00413	5,2	22 – 35 <sup>3)</sup>	11	42
3	0,00596	0,01133	8,6	32 – 45	13	60

## Dimensions

Size	A <sup>5)</sup>	$a_4$	F	$F_1$	$F_2$	$F_3$	$F_4$	$f_2$	$f_4$
01	9,5	7	57	– <sup>4)</sup>	65	80	50	5	46
1	10,9	10	82	90	95	105	65	6	67
2	12,6	10	103	105	110	105	65	6	84
3	14,7	19	118,5	125	130	135	85	7	104

Size	h	$h_2$ <sup>5)</sup>	k	$L_4$ <sup>5)</sup>	l	$l_0$	$l_1$	$o$ <sup>5)</sup>	p	$s_2$
01	33	37	1,0 <sup>2)</sup>	86	23	30	49	– <sup>4)</sup>	– <sup>4)</sup>	4
1	47	51	3,0	113	24	42	62	17,4	7,5	4
2	52	54	5,3	118	24	42	64	19,7	8	4
3	59	61,5	5,3	142,5	28,5	55	81	23,5	9	4

- 1) other sizes for lower and higher torques on request
- 2) countersunk screw with hexagon socket DIN 7991
- 3) up to Ø 33 keyway acc. DIN 6885/1, over Ø 33 keyway acc. DIN 6885/3.
- 4) thrust washer without keyway, limit switch is located at the control element-front face
- 5) the dimensions A; h; o refer to the hub edge

We reserve the right to make dimensional and design alterations.

## Order example:

To be included when ordering, please state:	Size	Type	Bore Ø $d^{H7}$	Bore Ø $d_2^{H7}$	With limit switch
Order number:		457._2_.0			see pages 36–38

- 01 – 3 → according to size  
 \* medium torque range. . . . . 5 → according to size  
 \* high torque range. . . . . 6 → 0 ratchetting clutch  
 → 5 synchronous clutch

\* see technical data, limiting torque for overload  $M_G$

**Example:** Order number 3 / 457.525.0 / 30 / 6885-1 / 40 / 6885-1 with limit switch 055.002.5

# EAS<sup>®</sup>-NC ratchetting clutch/synchronous clutch

## Mounting example

Fig. 1

### EAS<sup>®</sup>-NC Short hub

For the EAS<sup>®</sup>-NC short hub the drive elements are located over the deep groove ball bearing and attached to the pressure flange. If the resulting radial force of the drive element is nearly in the middle of the ball bearing, an additional support for the drive element is not necessary.

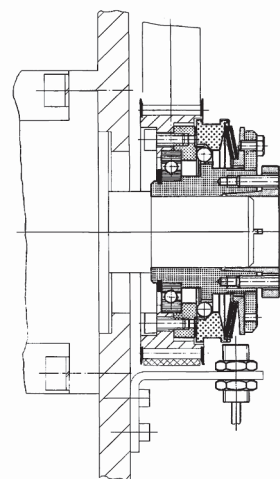

Fig. 2

### EAS<sup>®</sup>-NC with long projecting hub

For very wide drive elements or for elements with very small diameters our EAS<sup>®</sup>-NC with long projecting hub is recommended. In case of small diameters the drive element is attached to the pressure flange of the clutch via an intermediate flange supplied by the customer. The support for the drive element via a ball bearing, needle bearing or slide bearing depending on the mounting situation and available space can be used.

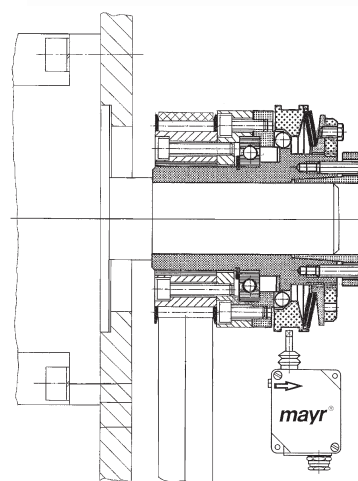

Fig. 3

### EAS<sup>®</sup>-NC Type 450.\_1\_.2

Two bearings-design for wide drive elements, whose application of force of the resulting radial force is in the middle of both bearings. In this case the drive element can be attached directly to the pressure flange without additional support.

#### Please Observe (for Figs. 1-3)

The screw quality and the tightening torque for the fixing screws on the drive element are to be selected so that the set limit torque can be transmitted with sufficient certainty via frictional locking.

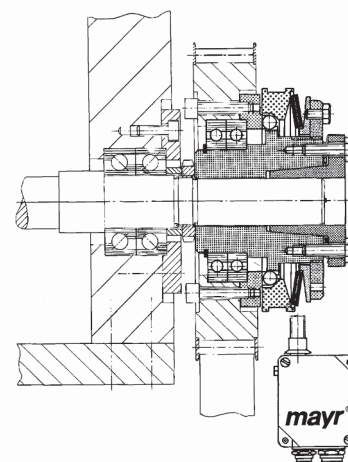
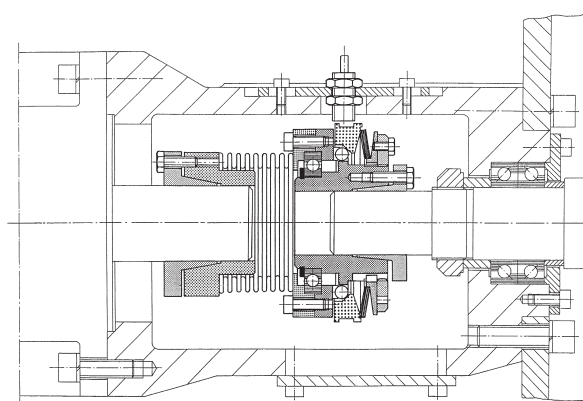

Fig. 4

### EAS<sup>®</sup>-NC with steel bellows coupling

EAS<sup>®</sup>-NC with torsionally rigid flexible steel bellows coupling for connection of two shafts. The coupling compensates axial, radial and angular shaft misalignments. It is torsionally rigid in a circumferential direction. In comparison to the EAS<sup>®</sup>-NC with ROBA<sup>®</sup>-D coupling the EAS<sup>®</sup>-NC steel bellows coupling has a low mass moment of inertia.

In the mounting example shown on the right side, the EAS<sup>®</sup>-NC with steel bellows coupling is mounted between motor and ball screw spindle. The torque is transmitted backlash-free until disengagement and drops immediately after the event of an overload. The contactless limit switch (initiator) gives signal to switch off the drive.



**Table: Coordination bore diameter d<sub>3</sub> / d<sub>4</sub> or the flexible coupling to transmittable torque „T<sub>KN</sub>“ with EAS<sup>®</sup>-NC Type 454.\_0\_.0 / 454.\_1\_.\_**

Size	Preferred bores Ø d <sub>3</sub> / Ø d <sub>4</sub> and appropriate transmittable torques T <sub>KN</sub> [Nm] of the friction tight of the clamping hubs / shrink discs with Type 454._0_.0																																	
	Ø 10		Ø 11		Ø 15		Ø 16		Ø 19		Ø 20		Ø 22		Ø 24		Ø 25		Ø 28		Ø 30		Ø 32		Ø 35		Ø 38		Ø 40		Ø 42		Ø 45	
	d <sub>3</sub>	d <sub>4</sub>	d <sub>3</sub>	d <sub>4</sub>	d <sub>3</sub>	d <sub>4</sub>	d <sub>3</sub>	d <sub>4</sub>	d <sub>3</sub>	d <sub>4</sub>	d <sub>3</sub>	d <sub>4</sub>	d <sub>3</sub>	d <sub>4</sub>	d <sub>3</sub>	d <sub>4</sub>	d <sub>3</sub>	d <sub>4</sub>	d <sub>3</sub>	d <sub>4</sub>	d <sub>3</sub>	d <sub>4</sub>	d <sub>3</sub>	d <sub>4</sub>	d <sub>3</sub>	d <sub>4</sub>	d <sub>3</sub>	d <sub>4</sub>	d <sub>3</sub>	d <sub>4</sub>	d <sub>3</sub>	d <sub>4</sub>	d <sub>3</sub>	d <sub>4</sub>
01	23	33	25	38	34	61	36	67	43	84	-	-	-	-	-	-	-	-	-	-	-	-	-	-	-	-	-	-	-	-	-	-	-	-
0	-	-	-	-	34	56	36	62	43	81	45	87	50	100	54	120	57	125	63	-	-	-	-	-	-	-	-	-	-	-	-	-	-	-
1	-	-	-	-	-	-	-	-	79	147	83	153	91	177	100	203	104	216	116	256	124	282	133	308	145	343	-	-	-	-	-	-	-	-
2	-	-	-	-	-	-	-	-	-	-	83	197	91	228	100	261	104	279	116	332	124	368	133	405	145	460	158	513	166	547	174	-	187	-
3	-	-	-	-	-	-	-	-	-	-	-	-	-	-	-	-	-	-	116	300	124	350	133	400	145	500	158	600	166	680	174	730	187	-

Table 1 The transmittable torque with clamping connection consider the max. play of fit with shaft fit k6/F7 resp. H7. The torque decreases with larger play to fit.

## Technical explanations

### Selection of size, calculation of energy, torque adjustment for horizontal servo axes

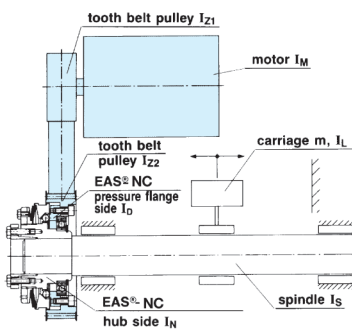

Fig. 1

$$I_g = I_M + I_{Z1} + (I_{Z2} + I_S + I_L) \cdot \left(\frac{n_2}{n_1}\right)^2$$

$$I_1 = I_D + I_{Z2} + (I_{Z1} + I_M) \cdot \left(\frac{n_1}{n_2}\right)^2$$

$$I_2 = I_N + I_S + I_L$$

I<sub>L</sub> from equation (7)

Preselection of the clutch  
M<sub>req.</sub> = 1,5 · M<sub>2</sub> [Nm]  
(M<sub>2</sub> from equation (4))

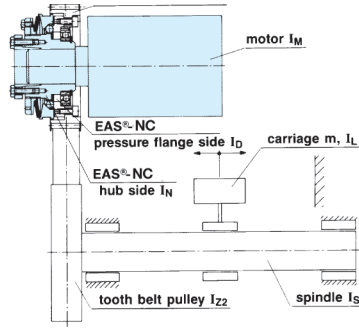

Fig. 2

$$I_g = I_M + I_{Z1} + (I_{Z2} + I_S + I_L) \cdot \left(\frac{n_2}{n_1}\right)^2$$

$$I_1 = I_M + I_N$$

$$I_2 = I_D + I_{Z1} + (I_{Z2} + I_S + I_L) \cdot \left(\frac{n_2}{n_1}\right)^2$$

I<sub>L</sub> from equation (7)

Preselection of the clutch  
M<sub>req.</sub> = 1,5 · M<sub>1</sub> [Nm]

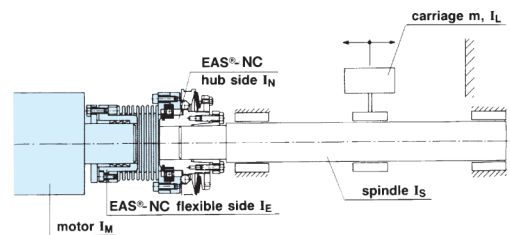

Fig. 3

$$I_g = I_M + I_{Ku} + I_S + I_L \quad [\text{kgm}^2] \quad (1)$$

$$I_1 = I_M + I_E \quad [\text{kgm}^2] \quad (2)$$

$$I_2 = I_N + I_S + I_L \quad [\text{kgm}^2] \quad (3)$$

I<sub>L</sub> from equation (7)

Preselection of the clutch  
M<sub>req.</sub> = 1,5 · M<sub>1</sub> [Nm]



# EAS<sup>®</sup>-NC ratchetting clutch/synchronous clutch

## Torque at spindle

$$M_2 = M_1 \cdot \frac{n_1}{n_2} \quad [\text{Nm}] \quad (4)$$

## Rate of feed of carriage

$$v = \frac{p \cdot n_2}{6 \cdot 10^4} \cdot \frac{m}{s} \quad (5)$$

## Angular velocity of motor shaft $\omega_1$ and spindle $\omega_2$

$$\omega_1 = \frac{n_1 \cdot \pi}{30} \quad [\text{s}^{-1}]; \quad \omega_2 = \frac{n_2 \cdot \pi}{30} \quad [\text{s}^{-1}] \quad (6)$$

## Mass of carriage reduced to the spindle

$$I_L = m \cdot \frac{v^2}{\omega_2^2} \quad [\text{kgm}^2] \quad (7)$$

$v$  from equation (5),  $\omega_2$  from equation (6)

## Energy with collision without EAS<sup>®</sup>-NC clutch

$$W_g = \frac{1}{2} \cdot I_g \cdot \omega_1^2 \quad [\text{J}] \quad (8)$$

$I_g$  from equation (1),  $\omega_1$  from equation (6)

## Energy with collision with EAS<sup>®</sup>-NC clutch

$$W_2 = \frac{1}{2} \cdot I_2 \cdot \omega_2^2 \quad [\text{J}] \text{ for arrangement as shown in fig. 1} \quad (9)$$

$$W_2 = \frac{1}{2} \cdot I_2 \cdot \omega_2^2 \quad [\text{J}] \text{ for arrangement as shown in figs. 2+3} \quad (9)$$

$I_2$  from equation (3),  $\omega_1$  and  $\omega_2$  from equation (6)

## Remaining residual energy

$$W_R = \frac{W_2}{W_g} \cdot 100 \quad [\%] \quad (10)$$

$W_g$  from equation (8),  $W_2$  from equation (9),

## Uncoupled energy

$$\Delta W = W_g - W_2 \quad [\text{J}] \quad (11)$$

$$\Delta W = 100 - W_R \quad [\%] \quad (12)$$

$W_g$  from equation (8),  $W_2$  from equation (9),

$W_R$  from equation (10)

## Designations:

$I_g$ [kgm <sup>2</sup> ]	total mass moment of inertia without EAS <sup>®</sup> -NC clutch related to the motor shaft
$I_1$ [kgm <sup>2</sup> ]	mass moment of inertia at the input side related to the shaft with the EAS <sup>®</sup> -NC clutch
$I_2$ [kgm <sup>2</sup> ]	mass moment of inertia at the output side (spindle side) related to the shaft with the EAS <sup>®</sup> -NC clutch
$I_M$ [kgm <sup>2</sup> ]	mass moment of inertia of the motor
$I_{Z1}$ [kgm <sup>2</sup> ]	mass moment of inertia of the tooth belt pulley at the motor side
$I_{Z2}$ [kgm <sup>2</sup> ]	mass moment of inertia of the second tooth belt pulley
$I_S$ [kgm <sup>2</sup> ]	mass moment of inertia of the spindle
$I_L$ [kgm <sup>2</sup> ]	mass of the carriage reduced to the spindle
$I_N$ [kgm <sup>2</sup> ]	mass moment of inertia of the EAS <sup>®</sup> -NC, hub side
$I_D$ [kgm <sup>2</sup> ]	mass moment of inertia of the EAS <sup>®</sup> -NC, pressure flange side
$I_E$ [kgm <sup>2</sup> ]	mass moment of inertia of the EAS <sup>®</sup> -NC, flexible coupling
$I_{Ku}$ [kgm <sup>2</sup> ]	mass moment of inertia of the two-shaft-connection before installing the EAS <sup>®</sup> -NC clutch
$M_1$ [Nm]	nominal torque of the motor
$M_2$ [Nm]	torque on the spindle
$M_B$ [Nm]	max. torque of the motor
$M_A$ [Nm]	required disengaging torque in the acceleration phase

## Required disengaging torque in the acceleration phase (axis horizontal)

$$M_A = M_B \cdot \frac{I_2}{I_2 + I_1} \cdot \frac{n_1}{n_2} \cdot * \quad [\text{Nm}] \quad (13)$$

$I_1$  from equation (2),  $I_2$  from equation (3)

\* speed ratio  $\frac{n_1}{n_2}$  is not valid for figures 2 and 3.

## Required disengaging torque in acceleration phase (axis aligned by choice)

$$\text{application acc. } M_A = \left( M_B \cdot \frac{n_1}{n_2} - M_L \right) \cdot \frac{I_2}{I_2 + I_1} + M_L \quad [\text{Nm}] \text{ to fig. 1}$$

$$\text{application acc. } M_A = \left( M_B - M_L \cdot \frac{n_2}{n_1} \right) \cdot \frac{I_2}{I_2 + I_1} + M_L \cdot \frac{n_2}{n_1} \quad [\text{Nm}] \text{ to fig. 2} \quad (14)$$

$$\text{application acc. } M_A = \left( M_B - M_L \right) \cdot \frac{I_2}{I_2 + I_1} + M_L \quad [\text{Nm}] \text{ to fig. 3}$$

$M_L$  from equation (15)

## Load torque from carriage mass with any alignment

$$M_L = \frac{m \cdot g \cdot \sin \alpha \cdot p}{2 \cdot \pi \cdot 1000} \quad [\text{Nm}] \quad (15)$$

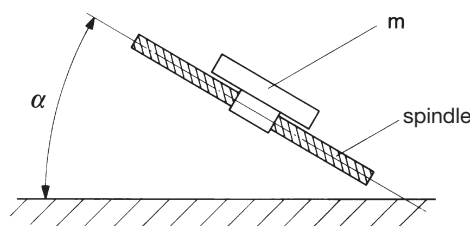

Fig. 4

## Setting of the limiting torque

$$M_G = 1,5 \cdot M_1 \quad [\text{Nm}] \text{ (arrangement as shown in figure 2)} \quad (16)$$

$$M_G = 1,5 \cdot M_2 \quad [\text{Nm}] \text{ (arrangement as shown in figs. 1 + 3)}$$

$M_2$  from equation (4)

Condition: The disengaging torque  $M_A$ , from equation (13) or (14) must be smaller than the torque  $M_G$  adjusted at the clutch (multiplied with the factor 1,2).

$M_G$ [Nm]	limiting torque for an overload
$M_L$ [Nm]	load torque from carriage mass with any alignment
$g$ [ $\frac{m}{s^2}$ ]	acceleration of fall
$m$ [kg]	mass of the carriage
$n_1$ [rpm]	drive speed of the motor (fast motion)
$n_2$ [rpm]	speed of the spindle (fast motion)
$p$ [mm]	ascent of the spindle
$v$ [ $\frac{m}{s}$ ]	rate of the feed of carriage
$W_g$ [J]	total energy in the case of a collision without EAS <sup>®</sup> -NC clutch
$W_2$ [J]	energy in the case of a collision with EAS <sup>®</sup> -NC clutch
$W_R$ [%]	remaining residual energy
$\Delta W$ [J]	uncoupled energy
$\Delta W$ [%]	uncoupled energy
$\omega_1$ [s <sup>-1</sup> ]	angular velocity of the motor shaft
$\omega_2$ [s <sup>-1</sup> ]	angular velocity of the spindle

## Calculation example

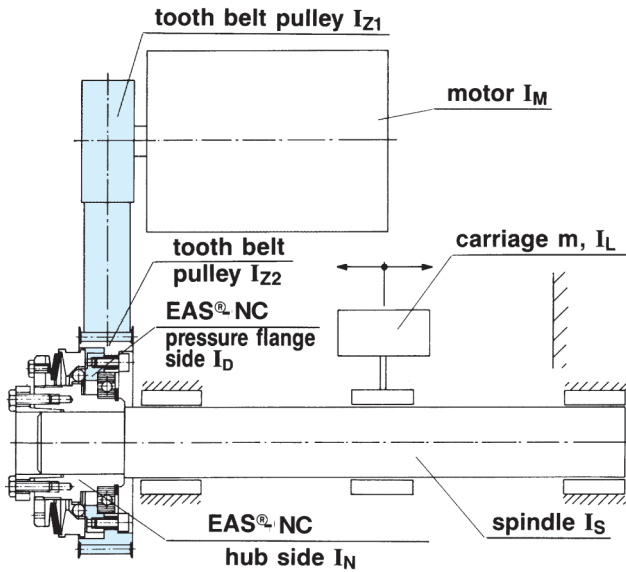

Fig. 1

Arrangement as shown in figure 1.

### Indications:

mass of the carriage	$m = 560 \text{ kg}$
mass moment of inertia of the motor	$I_M = 0,0037 \text{ kgm}^2$
mass moment of inertia of the tooth belt pulleys	$I_{Z1} = 0,0006 \text{ kgm}^2$
	$I_{Z2} = 0,01132 \text{ kgm}^2$
mass moment of inertia of the spindle	$I_S = 0,00067 \text{ kgm}^2$
drive speed of the motor	$n_1 = 2000 \text{ rpm}$
speed of the spindle	$n_2 = 1000 \text{ rpm}$
ascent of the spindle	$p = 10 \text{ mm}$
nominal torque of the motor	$M_1 = 14 \text{ Nm}$
max. torque of the motor	$M_B = 40 \text{ Nm}$

### Preselection of the clutch

$$M_{\text{req.}} = 1,5 \cdot M_2; \quad M_2 = M_1 \cdot \frac{n_1}{n_2} = 14 \text{ Nm} \cdot \frac{2000 \text{ rpm}}{1000 \text{ rpm}} = \mathbf{28 \text{ Nm}}$$

$$M_{\text{req.}} = 1,5 \cdot 28 \text{ Nm} = \mathbf{42 \text{ Nm}}$$

**Selected:** EAS<sup>®</sup>-NC size 1, Type 450.610.0  
torque range  $M_G = 30 \div 72 \text{ Nm}$   
(see technical data, page 10)

### Mass moment of inertia of the EAS<sup>®</sup>-NC

hub side	$I_N = 0,00120 \text{ kgm}^2$ (see techn. data, page 10)
pressure flange side	$I_D = 0,00039 \text{ kgm}^2$ (see techn. data, page 10)

### Rate of feed of carriage

$$v = \frac{p \cdot n_2}{6 \cdot 10^4} = \frac{10 \cdot 1000}{6 \cdot 10^4} \text{ m/s} = \mathbf{0,1667 \text{ m/s}}$$

### Angular velocity of the motor shaft $\omega_1$ and spindle $\omega_2$

$$\omega_1 = \frac{n_1 \cdot \pi}{30} = \frac{2000 \cdot \pi}{30} \text{ s}^{-1} = \mathbf{209 \text{ s}^{-1}}$$

$$\omega_2 = \frac{n_2 \cdot \pi}{30} = \frac{1000 \cdot \pi}{30} \text{ s}^{-1} = \mathbf{104,7 \text{ s}^{-1}}$$

### Mass of carriage reduced to the spindle

$$-I_L = m \cdot \frac{v^2}{\omega_2^2} = 560 \cdot \frac{0,1667^2}{104,7^2} \text{ kgm}^2 = \mathbf{0,00142 \text{ kgm}^2}$$

### Energy in the case of a collision without EAS<sup>®</sup>-NC clutch

$$I_g = I_M + I_{Z1} + (I_{Z2} + I_S + I_L) \cdot \left(\frac{n_2}{n_1}\right)^2 =$$

$$= 0,0037 + 0,0006 + (0,01132 + 0,00067 + 0,00142) \cdot \left(\frac{1000}{2000}\right)^2 =$$

$$= \mathbf{0,00765 \text{ kgm}^2}$$

$$W_g = 1/2 \cdot I_g \cdot \omega_1^2 = 1/2 \cdot 0,00765 \cdot 209^2 \text{ J} = \mathbf{167 \text{ J}}$$

### Energy in the case of a collision with EAS<sup>®</sup>-NC clutch

$$I_2 = I_N + I_S + I_L = 0,00120 + 0,00067 + 0,00142 \text{ kgm}^2 =$$

$$= \mathbf{0,00329 \text{ kgm}^2}$$

$$W_2 = 1/2 \cdot I_2 \cdot \omega_2^2 = 1/2 \cdot 0,00329 \cdot 104,7^2 \text{ J} = \mathbf{18 \text{ J}}$$

### Remaining residual energy

$$W_R = \frac{W_2}{W_g} \cdot 100 = \frac{18}{167} \cdot 100 = \mathbf{10,8 \%}$$

### Uncoupled energy

$$\Delta W = W_g - W_2 = 167 \text{ J} - 18 \text{ J} = \mathbf{149 \text{ J}}$$

$$\Delta W = 100 - W_R = 100 - 10,8 = \mathbf{89,2 \%}$$

### Required disengaging torque in the acceleration phase

$$I_1 = I_D + I_{Z2} + (I_{Z1} + I_M) \cdot \left(\frac{n_1}{n_2}\right)^2 =$$

$$= 0,00039 + 0,01132 + (0,0006 + 0,0037) \cdot \left(\frac{2000}{1000}\right)^2 =$$

$$= \mathbf{0,0289 \text{ kgm}^2}$$

$$M_A = M_B \cdot \frac{I_2}{I_2 + I_1} \cdot \frac{n_1}{n_2} = 40 \cdot \frac{0,00329}{0,00329 + 0,0289} \cdot \frac{2000}{1000} = \mathbf{8,2 \text{ Nm}}$$

### Setting of the limiting torque

$$M_G = 1,5 \cdot M_2 = 1,5 \cdot 28 \text{ Nm} = \mathbf{42 \text{ Nm}}$$

The disengaging torque  $1,2 \cdot M_A = 1,2 \cdot 8,2 \text{ Nm} = 9,84 \text{ Nm}$  is less than the set limiting torque  $M_G = 42 \text{ Nm}$ .

# Technical Explanations

## Indicated torque adjustment

The EAS<sup>®</sup>-NC torque limiting clutch offers the comfort of the indicated torque adjustment at the adjusting nut (not for sizes 02/03). The possibility for indication offers a substantially simplified torque adjustment and a simple monitoring of the set releasing value with an installed clutch.

- The limiting torque can be adjusted sensitively and indicated exactly by the fine pitch threaded graduated adjusting nut.
- The positive locking of the adjusting nut protects against self-acting unintended adjustment of the pre-set limiting torque. For EAS<sup>®</sup>-NC sizes 4–6 additional mechanical locking against blocking and backtwisting.

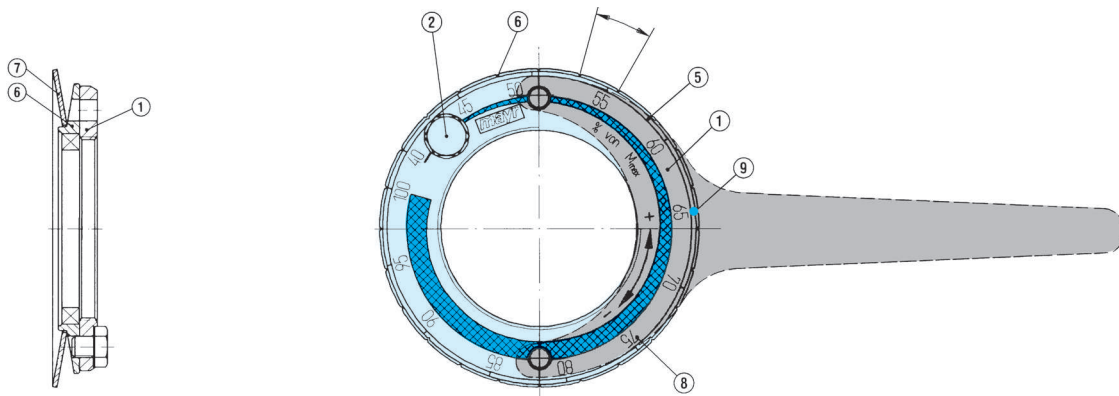

Fig. 1

## Important Note!

Depending on the kind of drive and drive constellation torque peaks (e. g. due to impact of the starting torque in case of asynchronous motors, load impacts, static friction or similar) can occur in the drive shaft which are clearly over the operating torque of the equipment (motor).

The customer has to consider the behaviour for the design or adjustment of the clutch.

## Torque adjustment

The adjustment is made by turning the adjusting nut. The cup springs operate in the negative area of their characteristics (see figure 2). A stronger pre-tension of the cup springs effects a decrease of the spring pressure. Turning the adjusting nut in a clockwise direction reduces the torque, and in anti-clockwise direction increases the torque (viewed in the direction of the nut - figure 1).

**EAS<sup>®</sup>-NC sizes 01–6** are adjusted **generally** at approx. 70%–75% of the corresponding max. torque and marked (calibrated) at the factory, if no other torque adjustment is required.

**EAS<sup>®</sup>-NC sizes 03+02** must be adjusted as per the included adjusting diagrams, if there is no adjustment or calibration made at the factory.

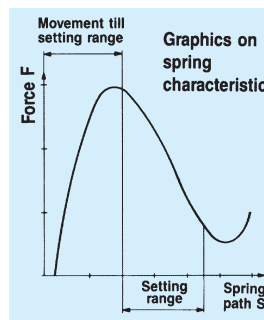

Fig. 2

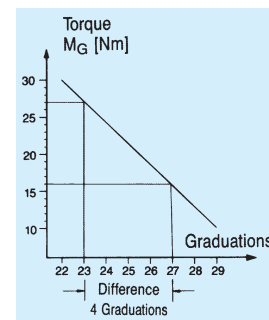

Fig. 3

## Torque adjustment by the aid of the adjusting diagram

- Grease thread and contact faces of the adjusting nut, retaining ring and hub.
- Manually screw on adjusting nut (1) until contact is made with the cup springs (7).
- Continue turning until the 4 graduations (5) at the circumference of the adjusting nut (1) and the notches in the retaining ring (6) are in line with each other.
- Using a face wrench, turn the adjusting nut (1) through the number of graduations corresponding to the required torque (fig. 3) (number of graduations as per setting diagram).
- The graduations at the circumference of the adjusting nut (5) and retaining ring (6) must remain in the same position.
- Put Loctite 242 onto the retaining screw (2) and screw it into the adjusting nut (1).

### Attention!!

**After dismantling the clutch (e.g. by changing the cup springs or cup spring layers) the clutch must be re-adjusted.**

## Adjusting the torque

Remove the retaining screw (2) (for sizes 4–6, 4 setscrews) from the adjusting nut.

Turn adjusting nut clockwise or anti-clockwise with the use of a face wrench according to the engraved graduation (for sizes 03 and 02 setting diagram) until the required torque is set. The required torque is achieved when the graduation in the retaining ring and the indication on the percentage in the adjusting nut (for sizes 03 and 02 from the graduations on the adjusting diagram) are overlapped. Afterwards the retaining screw or setscrew, respectively (locking by Loctite 242) are screwed into the adjusting nut again, whereby the 4 graduations in the adjusting nut and retaining ring must remain in the same position.

### Example:

Existing adjustment 65% of the max. torque.  
The customer requires 90% of the max. torque.

Turn adjusting nut anti-clockwise, as described above, until 90% of the graduation are in line with the notches in the retaining ring. If necessary, the alignment of the notches at the circumference of the adjusting nut must be overlapped with the graduations of the retaining ring.



## Application

This device is used to monitor mechanical movements and end positions. It is a controlling sensor for electronic and mechanical sequences. It also registers axial disengaging movements, e.g. on EAS<sup>®</sup>-clutches.

## Function

The pre-tensioned contact is discharged by actuating the switching lever: Contacts 11-14 (21-24) open, contacts 11-12 (21-22) close.

## Design

The microswitch is fitted into a light metal housing and is actuated by a switching lever. Operation is only possible in one direction.

The limit switch is fixed using M4 cap screws via two screw-on mounting links attached diagonally.



## Technical Data

Contact	1 changeover contact (special design: 2 changeover contacts)
Switching capacity	250 VAC / 15 A (with 2 contacts: 10A) 24 VDC / 6 A 60 VDC / 1,5 A 250 VDC / 0,2 A min. 12 VDC/10 mA
Contact material	AgCdO 90/10
Switching frequency	Max. 200 switching operations/min
Ambient temperature	-10 °C up to +85 °C
Protection	IP 54
Weight	275 g
Switching path setting	Using the adjusting screw (SW 7), the zero point can be moved right or left by max. 5 mm
Switching path	Advance travel: min. 0,15 to 0,5 mm Overtravel: max. 10 mm, depending on the zero point setting
Special Types	Different control lever lengths as well as a design with 2 changeover contacts are possible on request

## Dimensions (mm)

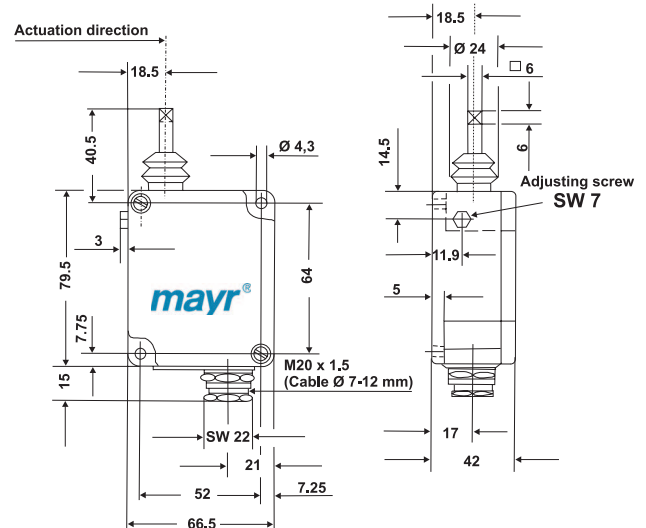

## Electrical Connection

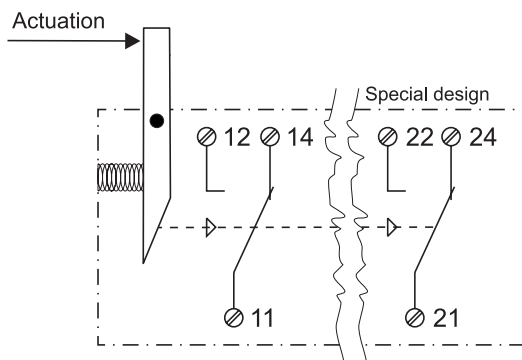

## Order Example

To be stated on order:	Type
Order number	055.000.5



# Limit switch Type 055.00\_.5 (Contactless)

## Application

This device is used for measuring and monitoring axial and radial disengaging movements, e.g. on EAS<sup>®</sup>-clutches. It acts as a control sensor for electronic and mechanical sequences.

## Function

When the sensor surface of the NAMUR sensor scans a metal control flag (damped), the signal relay is triggered, is de-energised and drops. Contacts 1 - 2 are opened. Damping is possible from all sides.

## Electrical Connection (Terminal)

1 - 2 - 3 Potential-free two-way contact  
5 - 6 Connection input voltage

## Design

The electronic amplifier is installed in a light metal housing. The limit switch is fixed using two screw-on mounting links attached diagonally with M4 cap screws.

## Technical Data

Input voltage 230 VAC, ±10 %, 50-60 Hz  
(dependent on design) 115 VAC, ±10 %, 50-60 Hz  
24 VDC, PELV, ±5 %, protected against reverse polarity, for overvoltage category II connection

Power consumption max. 1,5 VA

Ambient temperature -10 °C up to +60 °C limit switch  
-25 °C up to +60 °C NAMUR sensor

Protection IP 54

Conductor cross section max. 2,5 mm<sup>2</sup> / AWG 14

Weight 400 g / 14 oz

Protection fuse 0,1 A / fast acting at 24 VDC (in system)

Signalling relay Potential-free two-way contacts  
Contact load max. 250 VAC/12 A  
Contact material AgNi 90/10  
Max. frequency of operating cycles 20 Hz at min. load,  
0,1 Hz at max. load

NAMUR sensor internal Installed in a light metal housing, operating distance SN 2 mm, flush fitting, max. frequency of operating cycles 2 kHz, the zero point can be set per 1 mm by means of the lateral adjusting screw (SW 7).

NAMUR sensor external metal housing M12 x 1, operating distance SN 2 mm, flush fitting, max. frequency of operating cycles 2 kHz, standard cable length 2 m, max. 100m with special design, Protection IP 67

## Order example:

To be stated on order:	Type	Connected voltage
Order number:	055.00_.5	---

Contactless sensing 230 VAC  
Sensor external 1 115 VAC  
Sensor internal 2 24 VDC



## Dimensions (internal NAMUR sensor)

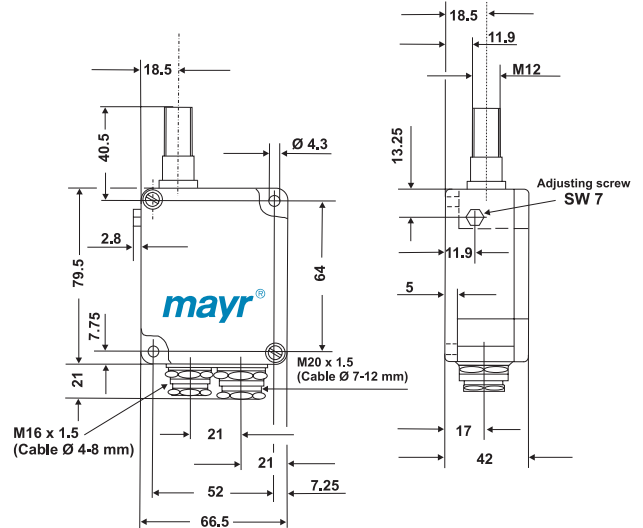

## Dimensions (external NAMUR sensor)

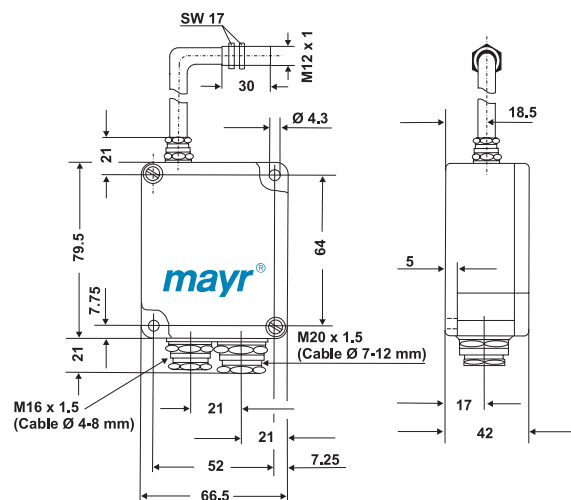

## Application

The limit switch is used to monitor and measure axial or radial mechanical movements and adjustments e.g. on EAS<sup>®</sup>-clutches. The device is suitable for clutches with a minimum stroke of 1,1 mm with radial actuation and 0,9 mm with axial actuation.

## Function

By actuating the metal tappet, contacts 11 – 12 are opened.

## Electrical Connection (Terminals)

11 – 12 NC contact

## Technical Data

Contact 1 x NC contact, forced disconnection contacts  $\ominus$

Contact (special design) additional 1 x NO contact, terminals 23 – 24, galvanically separated (Zb)

Contact-opening see switching travel diagram

Contact-closing see switching travel diagram

Contact load NC contact 250 VAC/2,5 A  
24 VDC/1 A  
min. 12 VDC/10 mA

Contact distance 250 VAC >1,25 mm

Contact distance 24 VDC <1,25 mm, min. 0,5 mm

Contact material Ag90Ni10

Max. input current acc. to DIN EN 60947-5-1  
AC15/DC13

Metal tappet travel max. 4 mm axial or radial

Switching frequency max. 100/Min.

Mechanical lifetime 1 x 10<sup>6</sup> switching cycles, unloaded

Conductor cross section 1,5 mm<sup>2</sup> / AWG 16

Ambient temperature -30 °C up to +80 °C

Protection IP 65

Protection insulation acc. to protection class II  $\square$

Housing thermoplastic, self extinguishing acc. to UL94-V0

Weight 120 g / 4.2 oz

## Installation

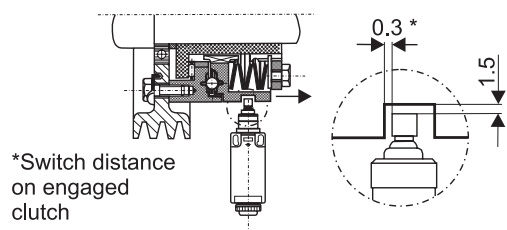

## Order Example

To be stated on order:	Type
<b>Order number</b>	<b>055.010.6</b>



## Dimensions (mm)

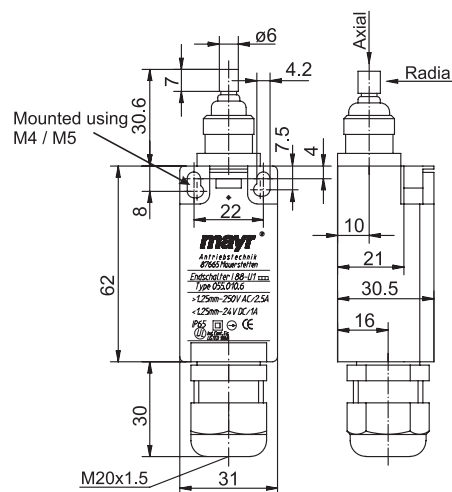

Fixed positioning for safety application with fixing screws 2 x M5 (DIN 921).

## Switching Travel Diagram

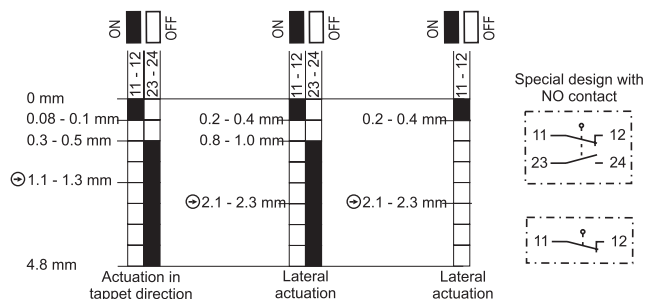

**Warning!** Do not install switch so that it drags and observe max. actuation travel (travel of metal tappet)

## Worldwide representation

### Headquarters

Chr. Mayr  
GmbH + Co. KG  
Eichenstraße 1  
87665 Mauerstetten  
Tel.: 49-83 41/8 04-241  
Fax: 49-83 41/804422  
info@mayr.de  
http://www.mayr.de

### Great Britain

**Mayr Transmissions Ltd.**  
Valley Road,  
Business Park  
Keighley, BD21 4LZ  
West Yorkshire  
Tel.: 0 15 35/66 39 00  
Fax: 0 15 35/66 32 61  
sales@mayr.co.uk

### Italy

**Mayr Italia S.r.l.**  
Viale Veneto, 3  
35020 Saonara (PD)  
Tel.: 0 49/8 79 10 20  
Fax: 0 49/8 79 10 22  
info@mayr-italia.it

### France

**Mayr France S.A.**  
Z.A.L. du Minopole  
BP 16  
62160 Bully-Les-Mines  
Tel.: 03.21.72.91.91  
Fax: 03.21.29.71.77  
contact@mayr.fr

### Switzerland

**Mayr Kupplungen AG**  
Tobeläckerstrasse 11  
8212 Neuhausen  
am Rheinfall  
Tel.: 0 52/6 74 08 70  
Fax: 0 52/6 74 08 75  
info@mayr.ch

### USA

**Mayr Corporation**  
4 North Street  
Waldwick  
NJ 07463  
Tel.: 2 01/4 45-72 10  
Fax: 2 01/4 45-80 19  
info@mayrcorp.com

### Singapore

**Mayr Transmission (S)**  
No. 8 Boon Lay Way  
Unit 03-06, TradeHub 21  
Singapore 609964  
Tel.: 0065/6560 1230  
Fax: 0065/6560 1000  
info@mayr.com.sg

### China

**Mayr Shanghai**  
Room 608, No. 1277  
West Zhongshan Road,  
Conch Building,  
200051 Shanghai, China  
Tel.: 021/62953138  
Fax: 021/62953137  
sales@mayr.com.cn

### Korea

**Mayr Korea**  
60-11, Woongnam-Dong  
ROK Changwon  
Rep. of Korea  
Tel.: 055/262-4024  
Fax: 055/262-4025  
info@mayrkorea.com

### Japan

**Sumitomo HI-PTC  
Sales Co., Ltd.**  
3-5-8, Kandakaji-Cho,  
Chiyoda-Ku  
Tokyo J101-0045  
Tel.: 03/52563091  
Fax: 03/52563098  
Gotou.k@sumiju.co.jp

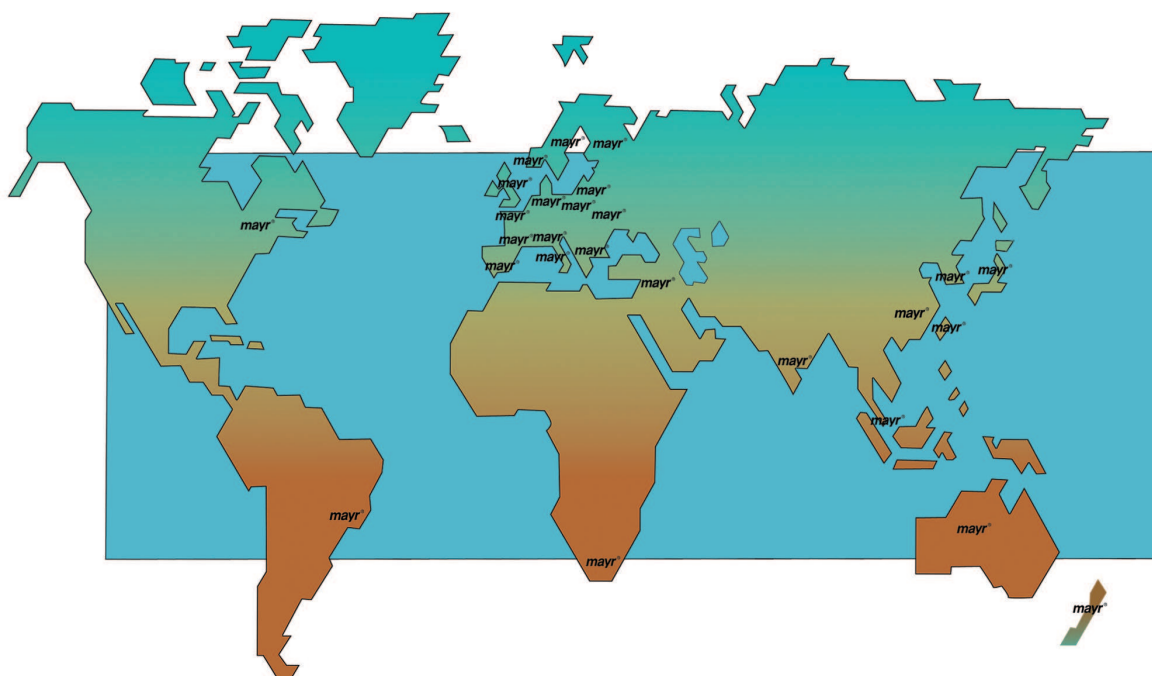

### Taiwan

German Tech Auto Co. Ltd.  
No. 58, Wu Chuan Road  
Wu-Ku Industrial Park  
Taipei Hsien, Taiwan  
Tel.: 02/2299 0237  
Fax: 02/2299 0239  
steve@zfgta.com.tw

### India

National Engineering  
Company (NENCO)  
J-225, M.I.D.C. Bhosari  
Pune 411 026  
Tel.: 0202/7474529  
Fax: 0202/7470229  
nenco@vsnl.com

### Australia

Transmission Australia Pty. Ltd.  
22 Corporate Ave,  
3178 Rowville, Victoria  
Australien  
Tel.: 039/755 4444  
Fax: 039/755 4411  
info@transaus.com.au

### South Africa

Torque Transfer  
Private Bag 9  
Elandsfontein 1406  
Tel.: 011/3458000  
Fax: 011/9740524  
torque@bearings.co.za

### Machine Tool

**Applications in China**  
DTC. Co.Ltd.,  
Block 5th, No. 1699,  
East Zhulu Road,  
201700 Shanghai, China  
Tel.: 021/59883978  
Fax: 021/59883979  
dctshanghai@online.sh.cn

Austria

Benelux States

Brazil

Canada

Czech Republic

Denmark

Finland

Greece

Hongkong

Hungary

Indonesia

Israel

Malaysia

New Zealand

Norway

Philippines

Poland

Romania

Russia

Slovakia

Slovenia

Spain

Sweden

Thailand

Turkey

Note:  
If a country is not  
shown, please refer  
to headquarters or  
our web site to be  
advised of the  
nearest responsible  
agent.

**mayr**<sup>®</sup>  
your reliable partner

# Product Summary



## Safety Clutches/ Overload Clutches

- ❑ **EAS<sup>®</sup>-Compact<sup>®</sup>/EAS<sup>®</sup>-NC**  
Positive locking and completely backlash-free torque limiting clutches
- ❑ **EAS<sup>®</sup>-smartic<sup>®</sup>**  
Cost-effective torque limiting clutches, quick installation
- ❑ **EAS<sup>®</sup>-element clutch/EAS<sup>®</sup>-elements**  
Load-disconnecting protection against high torques
- ❑ **EAS<sup>®</sup>-axial**  
Exact limitation of tensile and compressive forces
- ❑ **EAS<sup>®</sup>-Sp/EAS<sup>®</sup>-Sm/EAS<sup>®</sup>-Zr**  
Load-disconnecting torque limiting clutches with switching function
- ❑ **ROBA<sup>®</sup>-slip hub**  
Load holding, frictionally locked torque limiting clutches
- ❑ **ROBA<sup>®</sup>-contitorque**  
Magnetic continuous slip clutches

## Shaft Couplings

- ❑ **smartflex<sup>®</sup>**  
Perfect precision couplings for servo and stepping motors
- ❑ **ROBA<sup>®</sup>-ES**  
Backlash-free and damping for vibration-sensitive drives
- ❑ **ROBA<sup>®</sup>-DS/ROBA<sup>®</sup>-D**  
Backlash-free, torsionally rigid all-steel couplings
- ❑ **EAS<sup>®</sup>-control-DS**  
Cost-effective torque-measuring couplings-

## Electromagnetic Brakes/Clutches

- ❑ **ROBA-stop<sup>®</sup> standard**  
Multifunctional all-round safety brakes
- ❑ **ROBA-stop<sup>®</sup>-M motor brakes**  
Robust, cost-effective motor brakes
- ❑ **ROBA-stop<sup>®</sup>-S**  
Water-proof, robust monoblock brakes
- ❑ **ROBA-stop<sup>®</sup>-Z/ROBA-stop<sup>®</sup>-silenzio<sup>®</sup>**  
Doubly safe elevator brakes
- ❑ **ROBA<sup>®</sup>-diskstop<sup>®</sup>**  
Compact, very quiet disk brakes
- ❑ **ROBA<sup>®</sup>-topstop<sup>®</sup>**  
Brake systems for gravity loaded axes
- ❑ **ROBA<sup>®</sup>-linearstop**  
Backlash-free brake systems for linear motor axes
- ❑ **ROBATIC<sup>®</sup>/ROBA<sup>®</sup>-quick/ROBA<sup>®</sup>-takt**  
Electromagnetic clutches and brakes, clutch brake units

## DC Drives

- ❑ **tendo<sup>®</sup>-PM**  
Permanent magnet-excited DC motors
- ❑ **tendo<sup>®</sup>-SC**  
1 quadrant and 4 quadrant transistor controllers



Chr. Mayr GmbH + Co. KG  
Eichenstrasse 1  
D-87665 Mauerstetten  
Germany

Telephon 083 41/804-241  
Telefax 083 41/804 422  
<http://www.mayr.de>  
eMail: [info@mayr.de](mailto:info@mayr.de)

**mayr<sup>®</sup>**  
your reliable partner