

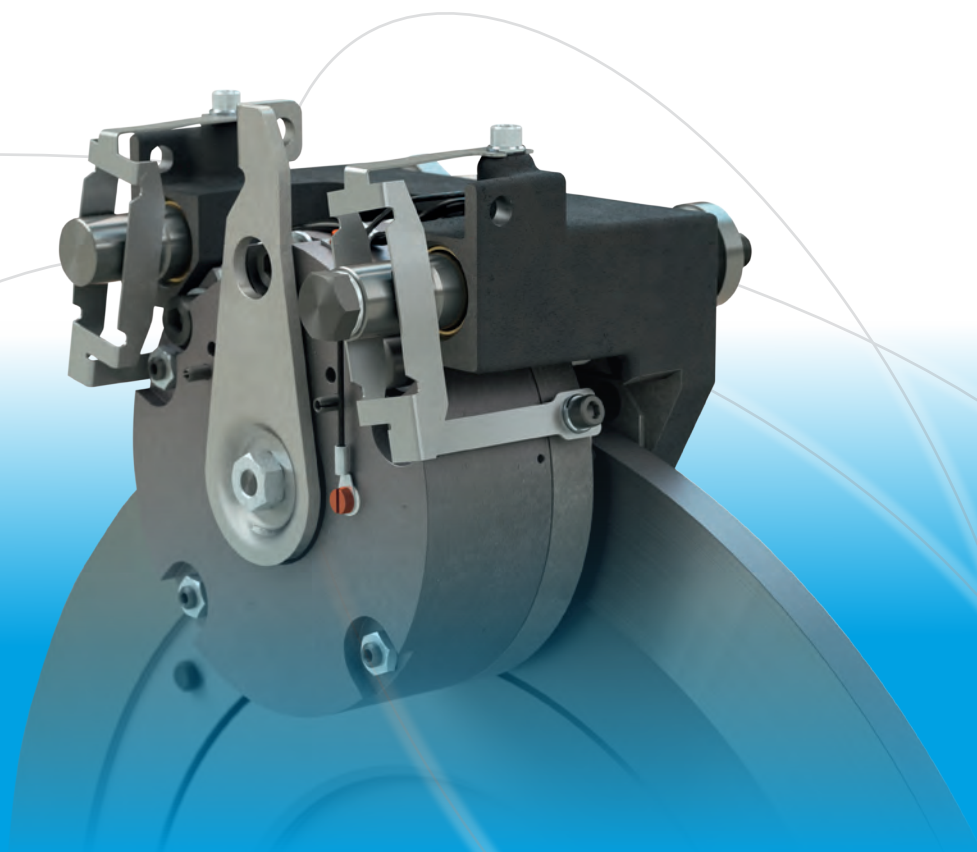

*your reliable partner*



**ROBA<sup>®</sup>-diskstop<sup>®</sup>**

# ROBA<sup>®</sup>-diskstop<sup>®</sup>

## Highest operational safety for people and load elevators



### Performance Characteristics

- **EU Type Examination Certificate according to the Elevator Directive 2014/33/EU (reference Standards EN 81-20 and EN 81-50)**
- **High energy absorption capability during dynamic braking actions**  
*Application possible in elevators with high speeds and large masses*
- **Can be released electrically and mechanically**  
*Without direct access to the drive (patented hand release)*
- **Microswitch query of the brake operating condition**  
*Safe switching function monitoring*
- **Patented switching noise damping**  
*For low-noise operation*
- **Patented active lining alignment mechanism on both sides available as an option**  
*Prevents rubbing noises, even in case of axial run-out deviations on the brake disk*
- **Simple and fast brake installation**  
*No adjustment work necessary*

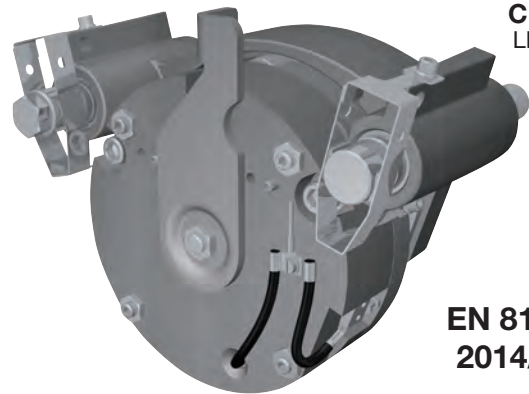

**EN 81-20/50  
2014/33/EU**  
-conform

### Function

The ROBA<sup>®</sup>-diskstop<sup>®</sup> brake is a spring applied, electro-magnetic safety brake.

Spring applied function:

In de-energised condition, the thrust springs (2) press the armature disk (3) against the brake disk (Fig. 1). The brake disk is held between the friction pads (4).

Electromagnetic:

Due to the magnetic force of the coil in the coil carrier (1), the armature disk (3) is attracted against the spring pressure to the coil carrier (1). The brake is released and the brake disk can rotate freely.

### Application

**As a brake for safe holding and EMERGENCY STOP operation**

**As part of the protection device against overspeed for the car moving in upwards direction or against uncontrolled movements when the elevator door is open**

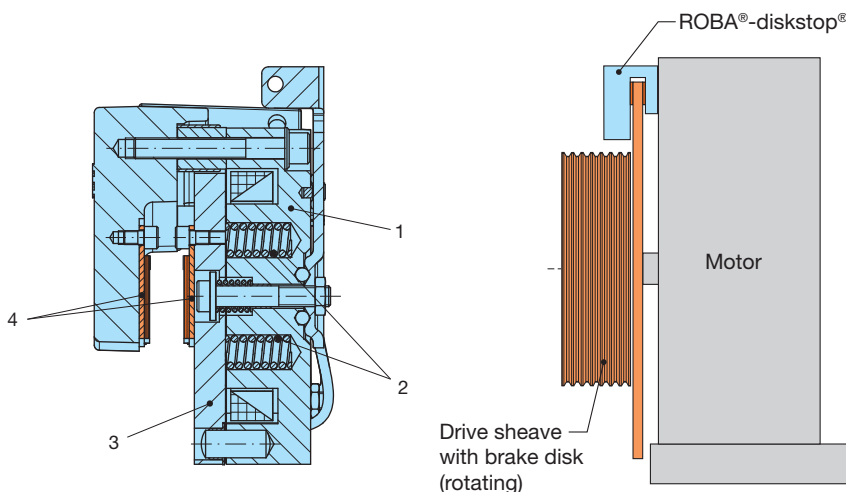

Fig. 1

Fig. 2

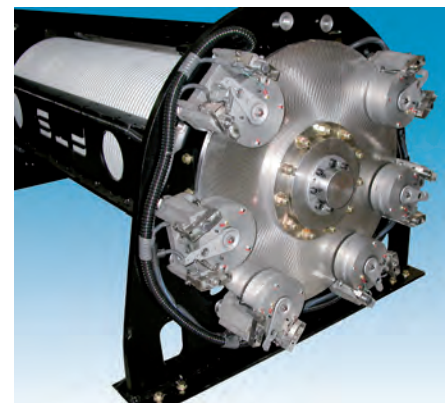

Fig. 3



On request ROBA<sup>®</sup>-diskstop<sup>®</sup> brakes can also be delivered with UL approval.



For a dual-circuit brake system acc. EN 81-20/50, at least two brakes are necessary.

# ROBA®-diskstop® – Sizes 6 – 8

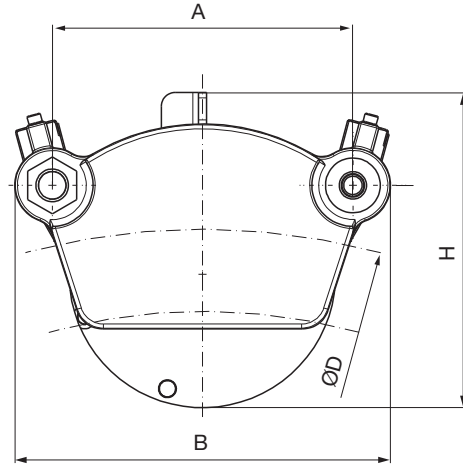
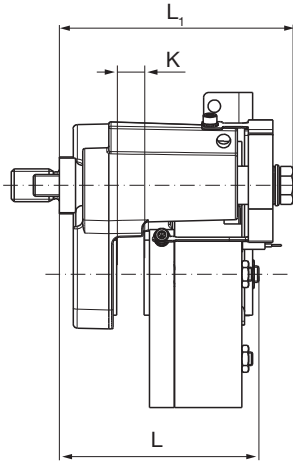

Technical Data and Dimensions			Size		
			6	7	8
<b>Braking force</b> <sup>1)2)</sup> <b>“performance-optimised”</b>	F <sub>Br</sub>	[N]	3232	3735	4890
Braking torque Example for brake disk diameter D = 1000 mm	M	[Nm]	1551	1774	2323
<b>Braking force</b> <sup>1)2)</sup> <b>“noise-optimised”</b>	F <sub>Br</sub>	[N]	2586	2980	3912
Braking torque Example for brake disk diameter D = 1000 mm	M	[Nm]	1241	1416	1858
<b>Braking force</b> <sup>1)</sup> <b>“without overexcitation”</b>	F <sub>Br</sub>	[N]	1939	2367	3166
Braking torque Example for brake disk diameter D = 1000 mm	M	[Nm]	931	1124	1504
<b>Effective friction diameter</b>	D <sub>eff</sub>	[mm]	D - 40	D - 50	D - 50
<b>Nominal power</b>		[W]	41	53	63
<b>Mass</b>		[kg]	14,6	19,4	23,5
<b>Brake disk</b>	<b>Outer diameter</b>	D	270 – ∞	390 – 1500	390 – ∞
	<b>Width</b> <sup>3)</sup>	K	15	15	20
<b>Brake</b>	<b>Bolt distance</b>	A	140	180	220
	<b>Length</b>	L	138	139	152
	<b>Length (with alignment mechanism)</b>	L <sub>1</sub>	161	161	173
	<b>Height</b>	H	198	225.5	230.5
	<b>Width</b>	B	184	229	275

1) Tolerance -0 % / +60 %

“performance-optimised” design:

For applications with high requirements on braking torque and performance density. Switching noises up to approx. 65 dB(A)

“noise-optimised” design:

For applications with high requirements on switching noises. Switching noises lower than 60 dB(A)

2) Overexcitation is necessary for operation!

3) Other brake disk widths possible – **Please contact the respective sales representative or the mayr® company directly.**

### Certification

The brakes have been type-examination tested as a braking device acting on the shaft of the traction sheave and as part of the protection device against overspeed for the car moving in upwards direction. For a dual-circuit brake system acc. EN 81-20/50, at least two brakes are necessary.

**Certificate number: 15656 (Sizes 6 – 8)**

### Order Number

performance-optimised design	<b>1</b>	<b>Hand release</b>	<b>0</b>	<b>Release monitoring</b>	<b>0</b>
noise-optimised design	<b>2</b>	Bowden cable	<b>1</b>	without	<b>1</b>
design without overexcitation	<b>3</b>	manually actuated		with	

  

<b>Size</b>	<b>Type series</b>	<b>Connection cable</b>	<b>Coil voltage</b> <sup>3)</sup>
6	Basic Type series <u>without</u> alignment mechanism and <u>without</u> guide bolts	0	104 [V DC]
7	Type series <u>without</u> alignment mechanism and with <u>screw-fastened</u> guide bolts	1	other voltages available on request
8	Type series <u>with</u> alignment mechanism and with <u>screw-fastened</u> guide bolts	2	
	Type series <u>without</u> alignment mechanism and with <u>inserted</u> guide bolts	3	
	Type series <u>with</u> alignment mechanism and with <u>inserted</u> guide bolts	4	

Example: 7 / 894.511.13 / 0 / 104 V DC

We reserve the right to make dimensional and constructional alterations.

# ROBA®-diskstop® – Sizes 9 – 10

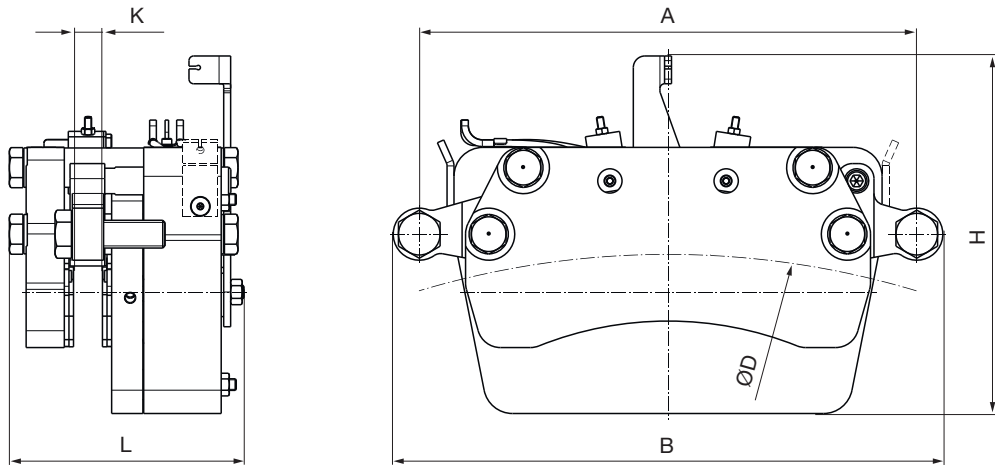

Technical Data and Dimensions				Size	
				9	10
<b>Braking force</b> <sup>1) 2)</sup>	F	[N]	8749	11182	
Braking torque Example for brake disk diameter D = 1000 mm	M	[Nm]	4025	5144	
<b>Effective friction diameter</b>	D <sub>eff</sub>	[mm]	D - 80	D - 80	
<b>Nominal power</b>		[W]	105	98	
<b>Mass</b>		[kg]	55	76	
<b>Brake disk</b>	<b>Outer diameter</b>	D [mm]	600 – 1200	650 – 1500	
	<b>Width</b> <sup>3)</sup>	K [mm]	25	25	
<b>Brake</b>	<b>Bolt distance</b>	A [mm]	400	430	
	<b>Length</b>	L [mm]	184	206.5	
	<b>Height</b>	H [mm]	298	309	
	<b>Width</b>	B [mm]	445	474	

- 1) Braking force tolerance: 0 % / + 60 %. Other braking force adjustments: see Table „Braking Force Adjustment“, page 4. Switching noises up to approx. 70 dB(A).
- 2) Overexcitation is necessary for operation!
- 3) Other brake disk widths possible – *Please contact the respective sales representative or the mayr® company directly.*

Braking Force Adjustment (Manufacturer-side) [N]					
Size					
9			10		
Braking force F		Braking torque M	Braking force F		Braking torque M
		Example for D = 1000 mm			Example for D = 1000 mm
	[N]	[Nm]		[N]	[Nm]
100%	8749	4025	100%	11182	5144
92%	8076	3715	95%	10620	4885
85%	7403	3405	82%	9103	4187
77%	6730	3096	68%	7586	3489
69%	6057	2786	54%	6068	2791
58%	5029	2313	41%	4551	2094

**Certification**

The brakes have been type-examination tested as a braking device acting on the shaft of the traction sheave and as part of the protection device against overspeed for the car moving in upwards direction. For a dual-circuit brake system acc. EN 81-20/50, at least two brakes are necessary.

**Certificate number:**  
**EU-BD 1075 (Size 9)**  
**EU-BD 1030 (Size 10)**

## Order Number

Hand release Bowden cable manually actuated		0 1	Release monitoring without with		0 1
<b>— / 8 9 4 . 5 1 — . 5 3 / — / —</b>					
Size 9 10		Connection cable		Coil voltage <sup>3)</sup> 104 [V DC] other voltages available on request	

4 Example: 10 / 894.511.53 / 0 / 104 V DC

We reserve the right to make dimensional and constructional alterations.

## ROBA®-diskstop® – Further Options

In addition to the standard brakes, *mayr*® power transmission provides a multitude of further designs, which cannot be described in detail in this catalogue.

Some of the most frequently requested options are:

- Terminal box
- Proximity switch as an alternative to microswitch for switching condition indication (release monitoring)
- Special hand release lever
- Cover

Please contact *mayr*® for further information.

### Terminal box

Terminal box (Item 1) for the wiring and storage of rectifiers (ROBA®-switch).

Also available on request are designs for a conduit connection.

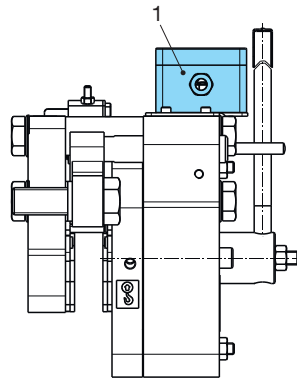

Fig. 1

### Release monitoring with proximity switch

When the magnetic coil is energised in the coil carrier (Item 2), the armature disk (Item 3) is attracted to the coil carrier (Item 2). The proximity switch (Item 1) emits a signal, the brake is released.

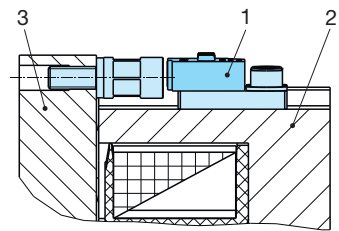

Fig. 2

The lifetime of the contactless release monitoring system is not dependent on the switching frequency. This option is wear-free, magnetic field resistant and absolutely reliable.

### Special hand release lever

In de-energised condition, the brake with hand release can be released manually.

Please contact *mayr*® for designing special hand release levers (Item 1).

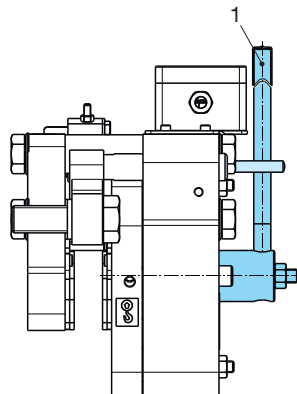

Fig. 3

### Cover

For certain designs, we offer a cover (Item 1).

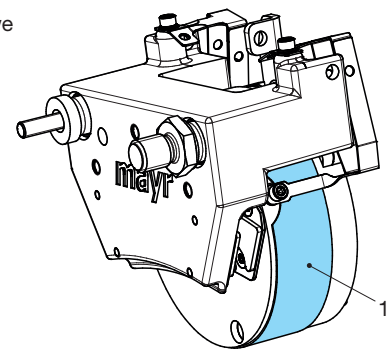

Fig. 4

## Technical Information on Brake Disk

- Brake disk material: steel or cast iron (for example EN-GJS-300, EN-GJS-600 ...)
- Axial run-out deviation of the brake disk: max. 0.25 mm for Sizes 6 – 8; max. 0.2 mm for Sizes 9 – 10
- Brake disk surface quality (friction surfaces):  $R_a = 3.2 \mu\text{m}$
- Brake disk width "K" acc. respective drawing, as standard with tolerance  $+0/-0.05 \text{ mm}$  for Sizes 6 – 8 and  $+0/-0.15 \text{ mm}$  for Sizes 9 – 10



Due to axial run-out deviations or tilting between the brake and the brake disk, the brake disk may rub against the friction linings.

**Before mounting the brake, the installation conditions and guidelines given in the Installation and Operational Instructions must be observed!**

# ROBA<sup>®</sup>-switch Type 017.\_00.2



## Application

ROBA<sup>®</sup>-switch fast acting rectifiers are used to connect DC consumers to alternating voltage supplies, for example electromagnetic brakes and clutches (ROBA-stop<sup>®</sup>, ROBA<sup>®</sup>-quick, ROBATIC<sup>®</sup>) as well as electromagnets, electrovalves, etc.

### Fast acting rectifier ROBA<sup>®</sup>-switch 017.\_00.2

- Consumer operation with overexcitation or power reduction
- Input voltage: 100 – 500 VAC
- Maximum output current  $I_{RMS}$ : 3 A at 250 VAC
- UL-approved

## Function

The ROBA<sup>®</sup>-switch is used for operation at an input voltage of between 100 and 500 VAC, depending on the size. It can switch internally from bridge rectification output voltage to half-wave rectification output voltage. The bridge rectification time can be modified from 0.05 to 2 seconds by exchanging the external resistor ( $R_{ext}$ ).

## Electrical connection (Terminals)

- 1 + 2 Input voltage (fitted protective varistor)
- 3 + 4 Connection for external contact for DC-side switch-off
- 5 + 6 Output voltage (fitted protective varistor)
- 7 + 8  $R_{ext}$  for bridge rectification time adjustment

## Technical data

Input voltage	see Table 1
Output voltage	see Table 1
Protection	IP65 components, IP20 terminals, IP10 $R_{ext}$
Terminal nom. cross-section	1.5 mm <sup>2</sup> (AWG 22-14)
Ambient temperature	-25 °C up to +70 °C
Storage temperature	-40 °C up to +70 °C

ROBA<sup>®</sup>-switch Sizes, Table 1

		Size			
		Type 017.000.2		Type 017.100.2	
		10	20	10	20
Input voltage ± 10%	$U_{AC}$ [VAC]	100–250	200–500	100–250	200–500
Output voltage	$U_{bridge}$ [VDC]	90–225	180–450	90–225	180–450
	$U_{half-wave}$ [VDC]	45–113	90–225	45–113	90–225
Output current	at ≤ 45 °C				
	at max. 70 °C				
	$I_{RMS}$ [A]	2.0	1.8	3.0	2.0
	$I_{RMS}$ [A]	1.0	0.9	1.5	1.0
Conformity markings					

## Order Number

___ / 0 1 7 . ___ 0 0 . 2	
▲	▲
<b>Size</b>	<b>UL-approved</b>
10	0 up to 300 V
20	1 up to 500 V



## Dimensions (mm)

Type 017.000.2

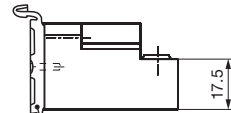
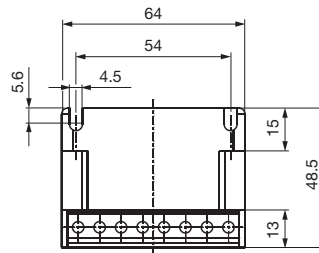
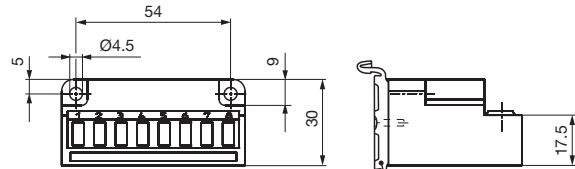

Accessories:  
Mounting bracket set for 35 mm rail acc. EN 60715:  
Article No. 1802911

Type 017.100.2

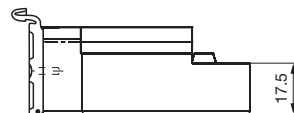
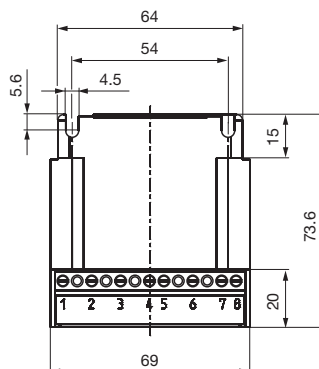
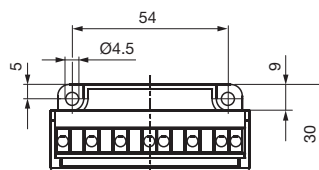

Accessories:  
Mounting bracket set for 35 mm rail acc. EN 60715:  
Article No. 1802911

## ROBA®-diskstop® – Guidelines



**Guidelines on the Declaration of Conformity:** A conformity evaluation has been carried out for the product (electromagnetic safety brake) in terms of the EU Low Voltage Directive 2014/35/EU. The Declaration of Conformity is laid out in writing in a separate document and can be requested if required.

**Guidelines on the EMC Directive (2014/30/EU):** The product cannot be operated independently according to the EMC directive. Due to their passive state, brakes are also non-critical equipment according to the EMC. Only after integration of the product into an overall system can this be evaluated in terms of the EMC. For electronic equipment, the evaluation has been verified for the individual product in laboratory conditions, but not in the overall system.

**Guidelines on the Machinery Directive (2006/42/EC):** The product is a component for installation into machines according to the Machinery Directive 2006/42/EC. The brakes can fulfil the specifications for safety-related applications in connection with other elements. The type and scope of the required measures result from the machine risk analysis. The brake then becomes a machine component and the machine manufacturer assesses the conformity of the safety device to the directive. It is forbidden to start use of the product until you have ensured that the machine accords with the regulations stated in the directive.

**Guidelines on the ATEX Directive:** Without a conformity evaluation, this product is not suitable for use in areas where there is a high danger of explosion. For application of this product in areas where there is a high danger of explosion, it must be classified and marked according to Directive 2014/34/EU.

### Safety Regulations

Brakes may generate several risks, among others:



During the risk assessment, the dangers involved must be evaluated and removed by taking appropriate protective measures.

**To prevent injury or damage, only specialist personnel are allowed to work on the components.** They must be familiar with the dimensioning, transport, installation, inspection of the brake equipment, initial operation, maintenance and disposal according to the relevant standards and regulations.

### Application Conditions



The catalogue values are guideline values which have been determined in test facilities. It may be necessary to carry out your own tests for the intended application.

When dimensioning the brakes, please remember that installation situations, braking torque fluctuations, permitted friction work, bedding-in condition / conditioning of the brake linings and wear as well as general ambient conditions can all affect the given values. These factors should therefore be carefully assessed, and alignments made accordingly.

- Mounting dimensions and connection dimensions must be adjusted according to the size of the brake at the place of installation.
- The brakes are designed for a relative duty cycle of 60 %. A duty cycle > 60 % leads to higher temperatures, which cause premature ageing of the noise damping and therefore lead to an increase in switching noises.
- The braking torque is dependent on the bedding-in condition of the brake. Bedding in / conditioning of the friction linings is necessary.
- The brakes are only designed for dry running. The torque is lost if the friction surfaces come into contact with oil, grease, water or similar substances or foreign bodies.
- Manufacturer-side corrosion protection of the metallic surfaces.
- The rotors may rust up and seize up in corrosive ambient conditions and/or after longer downtimes.

**Ambient Temperature -5 °C up to +40 °C**

### Protection

**(mechanical) IP10:** Protection against large body surfaces and large foreign bodies > 50 mm in diameter. No protection against water.

**(electrical) IP54:** Dust-proof and protected against contact as well as against water spray from any direction.

### Intended Use

This safety brake is intended for use in electrically operated elevators and goods elevators. Furthermore, this brake can be used as a braking device acting on the traction sheave or the shaft of the traction sheave, as part of the protection device against overspeed for the car moving in upwards direction and as a braking element against unintended car movement.

### Guidelines for Electromagnetic Compatibility (EMC)

In accordance with the EMC directives 2014/30/EU, the individual components produce no emissions. However, functional components e.g. mains-side energisation of the brakes with rectifiers, phase demodulators, ROBA®-switch devices or similar controls can produce disturbance which lies above the allowed limit values. For this reason it is important to read the Installation and Operational Instructions very carefully and to keep to the EMC Directives.

### Standards, Directives and Regulations Used and To Be Applied

DIN VDE 0580	Electromagnetic devices and components, general specifications
2014/35/EU	Low Voltage Directive
CSA C22.2 No. 14-2010	Industrial Control Equipment
UL 508 (Edition 17)	Industrial Control Equipment
2014/33/EU	Elevator Directive
EN 81-20	Safety rules for the construction and installation of lifts –Part 20: Passenger and goods passenger lifts
EN 81-50	Safety rules for the construction and installation of lifts - Examinations and tests – Part 50: Design rules, calculations, examinations and tests of lift components
EN ISO 12100	Safety of machinery – General principles for design - Risk assessment and risk reduction
EN 61000-6-4	Interference emission
EN 12016	Interference immunity (for elevators, escalators and moving walkways)

### Liability

- The information, guidelines and technical data in these documents were up to date at the time of printing. Demands on previously delivered brakes are not valid.
- Liability for damage and operational malfunctions will not be taken if:
  - the Installation and Operational Instructions are ignored or neglected.
  - the brakes are used inappropriately.
  - the brakes are modified.
  - the brakes are worked on unprofessionally.
  - the brakes are handled or operated incorrectly.

### Guarantee

- The guarantee conditions correspond with the Chr. Mayr GmbH + Co. KG sales and delivery conditions.
- Mistakes or deficiencies are to be reported to *mayr®* at once!

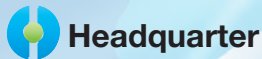

## Headquarter

**Chr. Mayr GmbH + Co. KG**  
**Eichenstraße 1, D-87665 Mauerstetten**  
**Tel.: +49 83 41/8 04-0, Fax: +49 83 41/80 44 21**  
**www.mayr.com, E-Mail: info@mayr.com**



*your reliable partner*

## Service Germany/Austria

### Baden-Württemberg

Esslinger Straße 7  
 70771 Leinfelden-Echterdingen  
 Tel.: 07 11/78 26 26 40  
 Fax: 07 11/78 26 26 39

### Bavaria

Industriestraße 51  
 82194 Gröbenzell  
 Tel.: 0 81 42/50 19 80-7

### Chemnitz

Bornaer Straße 205  
 09114 Chemnitz  
 Tel.: 03 71/4 74 18 96  
 Fax: 03 71/4 74 18 95

### Franken

Unterer Markt 9  
 91217 Hersbruck  
 Tel.: 0 91 51/81 48 64  
 Fax: 0 91 51/81 62 45

### Kamen

Herbert-Wehner-Straße 2  
 59174 Kamen  
 Tel.: 0 23 07/24 26 79  
 Fax: 0 23 07/24 26 74

### North

Schiefer Brink 8  
 32699 Extertal  
 Tel.: 0 57 54/9 20 77  
 Fax: 0 57 54/9 20 78

### Rhine-Main

Kreuzgrundweg 3a  
 36100 Petersberg  
 Tel.: 06 61/96 21 02 15

### Austria

Pummerinplatz 1, TIZ I, A27  
 4490 St. Florian, Austria  
 Tel.: 0 72 24/2 20 81-12  
 Fax: 0 72 24/2 20 81 89

## Branch Offices

### China

Mayr Zhangjiagang  
 Power Transmission Co., Ltd.  
 Fuxin Road No.7, Yangshe Town  
 215637 Zhangjiagang  
 Tel.: 05 12/58 91-75 67  
 Fax: 05 12/58 91-75 66  
 info@mayr-ptc.cn

### Great Britain

Mayr Transmissions Ltd.  
 Valley Road, Business Park  
 Keighley, BD21 4LZ  
 West Yorkshire  
 Tel.: 0 15 35/66 39 00  
 Fax: 0 15 35/66 32 61  
 sales@mayr.co.uk

### France

Mayr France S.A.S.  
 Z.A.L. du Minopole  
 Rue Nungesser et Coli  
 62160 Bully-Les-Mines  
 Tel.: 03.21.72.91.91  
 Fax: 03.21.29.71.77  
 contact@mayr.fr

### Italy

Mayr Italia S.r.l.  
 Viale Veneto, 3  
 35020 Saonara (PD)  
 Tel.: 049/879 10 20  
 Fax: 049/879 10 22  
 info@mayr-italia.it

### Singapore

Mayr Transmission (S) PTE Ltd.  
 No. 8 Boon Lay Way Unit 03-06,  
 TradeHub 21  
 Singapore 609964  
 Tel.: 00 65/65 60 12 30  
 Fax: 00 65/65 60 10 00  
 info@mayr.com.sg

### Switzerland

Mayr Kupplungen AG  
 Tobeläckerstraße 11  
 8212 Neuhausen am Rheinfall  
 Tel.: 0 52/6 74 08 70  
 Fax: 0 52/6 74 08 75  
 info@mayr.ch

### USA

Mayr Corporation  
 10 Industrial Avenue  
 Mahwah  
 NJ 07430  
 Tel.: 2 01/4 45-72 10  
 Fax: 2 01/4 45-80 19  
 info@mayrcorp.com

### Turkey

Representative Office Turkey  
 Kucukbakkalkoy Mah.  
 Brandium Residence R2  
 Blok D:254  
 34750 Atasehir - Istanbul, Turkey  
 Tel.: 02 16/2 32 20 44  
 Fax: 02 16/5 04 41 72  
 info@mayr.com.tr

## Representatives

### Australia

Drive Systems Pty Ltd.  
 8/32 Melverton Drive  
 Hallam, Victoria 3803  
 Australien  
 Tel.: 0 3/97 96 48 00  
 info@drivesystems.com.au

### India

National Engineering  
 Company (NENCO)  
 J-225, M.I.D.C.  
 Bhosari Pune 411026  
 Tel.: 0 20/27 13 00 29  
 Fax: 0 20/27 13 02 29  
 nenco@nenco.org

### Japan

MATSUI Corporation  
 4-7 Azabudai, 2-Chome,  
 Minatoku  
 Tokyo 106-8641  
 Tel.: 03/35 86-41 41  
 Fax: 03/32 24 24 07  
 info@matsui-corp.co.jp

### Netherlands

Groneman BV  
 Amarilstraat 11  
 7554 TV Hengelo OV  
 Tel.: 074/2 55 11 40  
 Fax: 074/2 55 11 09  
 aandrijftechniek@groneman.nl

### Poland

Wamex Sp. z o.o.  
 ul. Pozaryskiego, 28  
 04-703 Warszawa  
 Tel.: 0 22/6 15 90 80  
 Fax: 0 22/8 15 61 80  
 wamex@wamex.com.pl

### South Korea

Mayr Korea Co. Ltd.  
 15, Yeondeok-ro 9beon-gil  
 Seongsan-gu  
 51571 Changwon-si  
 Gyeongsangnam-do. Korea  
 Tel.: 0 55/2 62-40 24  
 Fax: 0 55/2 62-40 25  
 info@mayrkorea.com

### Taiwan

German Tech Auto Co., Ltd.  
 No. 28, Fenggong Zhong Road,  
 Shengang Dist.,  
 Taichung City 429, Taiwan R.O.C.  
 Tel.: 04/25 15 05 66  
 Fax: 04/25 15 24 13  
 abby@zfgta.com.tw

### Czech Republic

BMC - TECH s.r.o.  
 Hviezdoslavova 29 b  
 62700 Brno  
 Tel.: 05/45 22 60 47  
 Fax: 05/45 22 60 48  
 info@bmc-tech.cz

## More representatives:

Belgium, Brazil, Canada, Colombia, Croatia, Denmark, Finland, Greece, Hongkong, Hungary, Indonesia, Israel, Luxembourg, Malaysia, Mexico, New Zealand, Norway, Philippines, Portugal, Romania, Russia, Slovakia, Slovenia, South Africa, Spain, Sweden, Thailand

You can find the complete address for the representative responsible for your area under [www.mayr.com](http://www.mayr.com) in the internet.