

# ROBA<sup>®</sup>-diskstop<sup>®</sup>

Safety brakes for brake disks

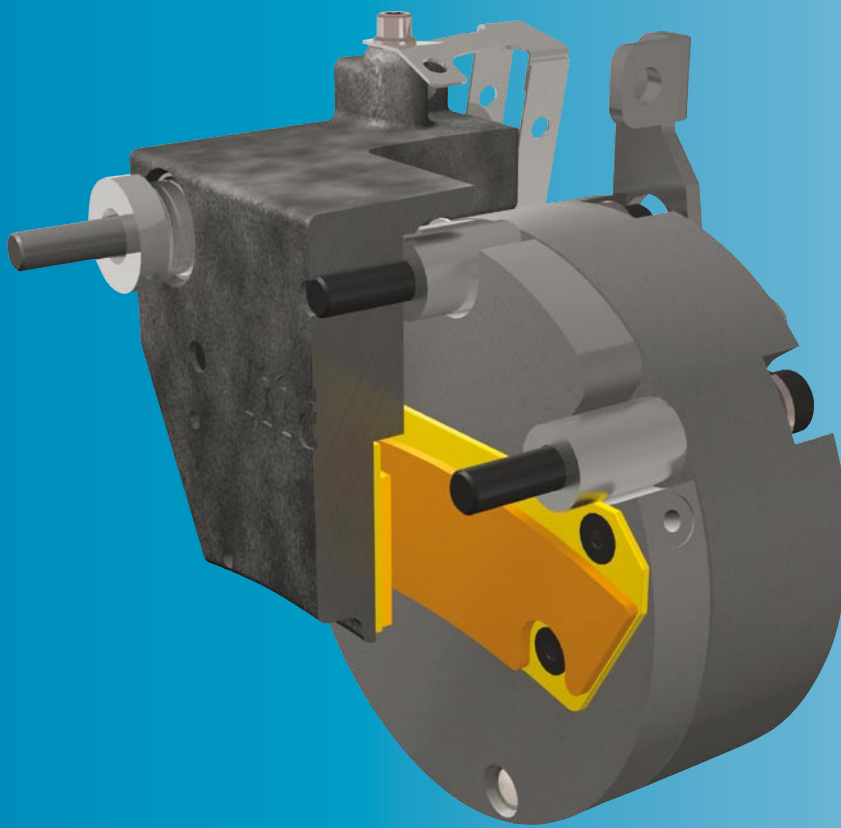

EN 81-1



- *Noise-minimised operation*
- *Attractive solution for large braking torques*
- *Mechanical and electrical release*
- *Redundancy acc. EN 81 when using an arrangement with two brakes*

[www.mayr.de](http://www.mayr.de)

K.894.V08.GB

**mayr**<sup>®</sup>  
your reliable partner

# ROBA®-diskstop®

Highest operational safety for people and load elevators

## Performance Characteristics

- **Prototype approved acc. elevator standard EN81-1**
- **High energy absorption capability during dynamic braking actions**  
*Application possible in elevators with high speeds and large masses*
- **Can be released electrically and mechanically**  
*Without direct access to the drive (patented hand release)*
- **Microswitch query of the brake operating condition**  
*Safe switching function monitoring*
- **Patented switching noise damping**  
*For low-noise operation*
- **Patented active lining alignment mechanism on both sides available as an option**  
*Prevents grinding noises, even in case of axial run-out deviations on the brake disk*
- **Simple and fast brake installation**  
*No adjustment work necessary*

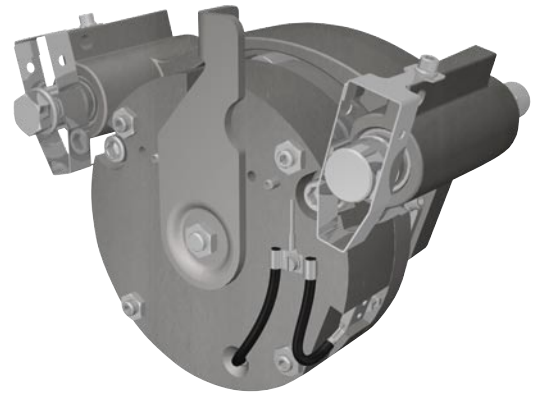

## Function

The ROBA®-diskstop® brakes are spring applied, electromagnetic safety brakes.

### Spring applied:

In de-energised condition, thrust springs (2) press the armature disk (3) against the brake disk (Fig. 1). The brake disk is held between the friction pads (4).

### Electromagnetic:

Due to the magnetic force of the coil in the coil carrier (1), the armature disk (3) is attracted against the spring force to the coil carrier (1). The brake is released and the brake disk can rotate freely.

## Application

As a brake for safe holding and EMERGENCY STOP operation.

As a protective device against excessive upward-moving cage speeds or against uncontrolled movements when the elevator door is open.



For a dual-circuit brake system acc. EN 81-1, at least two brakes are necessary.

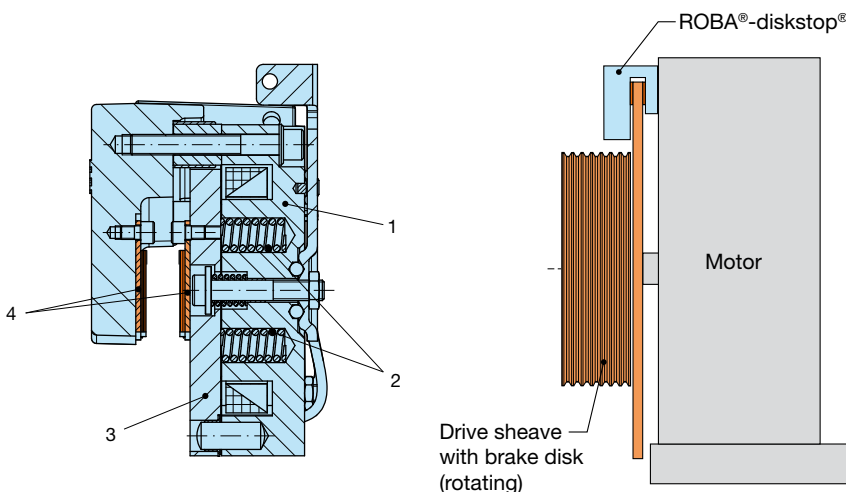

Fig. 1

Fig. 2

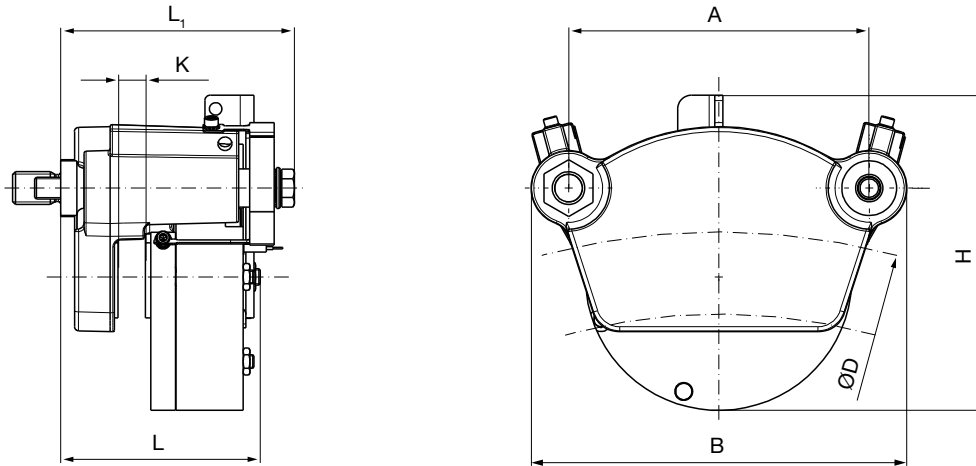

Fig. 3



On request ROBA®-diskstop® brakes can also be delivered with UL approval.

Sizes 6 – 8



Technical Data and Dimensions			Size		
			6	7	8
Braking torque <sup>1)</sup> “performance-optimised” Example for brake disk diameter D = 1000 mm	M	[Nm]	1,615 x (D - 40) 1550	1,870 x (D - 50) 1777	2,450 x (D - 50) 2328
	M	[Nm]	1,296 x (D - 40) 1244	1,615 x (D - 50) 1534	1,960 x (D - 50) 1862
Nominal power		[W]	41	53	63
Brake disk	Outer diameter	D [mm]	270 – ∞	390 – 1500	390 – ∞
	Width <sup>2)</sup>	K [mm]	15	15	20
Brake	Bolt distance	A [mm]	140	180	220
	Length	L [mm]	125	138	146
	Length (with alignment mechanism)	L <sub>1</sub> [mm]	161	161	173
	Height	H [mm]	198	225,5	229
	Width	B [mm]	184	227	275

- 1) Tolerance -0 % / +60 %  
 “performance-optimised” design:  
 For applications with high requirements on braking torque and performance density. Switching noises up to approx. 65 dB(A)  
 “noise-optimised” design:  
 For applications with high requirements on switching noises. Switching noises lower than 60 dB(A)
- 2) Other brake disk widths possible – **Please contact the respective sales representative or the mayr® company directly.**
- 3) Overexcitation is necessary for operation!

We reserve the right to make dimensional and constructional alterations.

**Certificate**

The brakes were prototype-inspected for their effect as a brake assembly on the drive sheave shaft and as part of the protective assembly against excessive upward-moving cage speeds. For a dual-circuit brake system acc. EN 81-1, at least two brakes are necessary.

**Certificate number:**  
**08495/2 (Sizes 6 – 8)**

**Order Number**

	<b>Hand release</b>		<b>Release monitoring</b>	
	Hand release, Bowden cable	<b>0</b>	without	<b>0</b>
	Hand release, actuated manually	<b>1</b>	with	<b>1</b>
▽				
_	/	8	9	4
_	.	5	1	_
_	.	_	3	/
_	/	_	/	_
▲		▲	▲	▲
<b>Size</b>	<b>Type series</b>			<b>Coil voltage <sup>3)</sup></b>
6	Basic Type series <u>without</u> alignment mechanism and <u>without</u> guide bolts			104 [V DC]
7	Type series <u>without</u> alignment mechanism and with <u>screw-fastened</u> guide bolts			Deviating voltages on request
8	Type series <u>with</u> alignment mechanism and with <u>screw-fastened</u> guide bolts			
	Type series <u>without</u> alignment mechanism and with <u>inserted</u> guide bolts			
	Type series <u>with</u> alignment mechanism and with <u>inserted</u> guide bolts			

Example: 7 / 894.511.13 / 0 / 104 V DC

Size 10

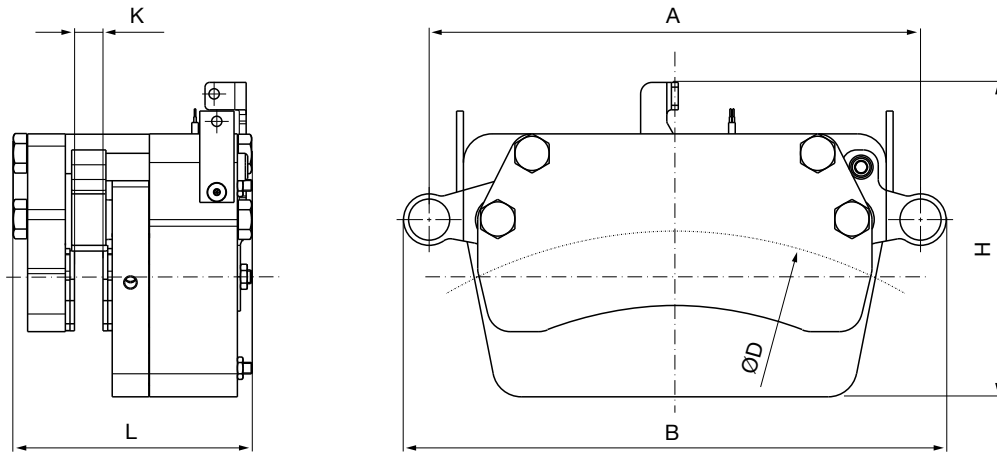

Technical Data and Dimensions				Size
				10
Braking torque <sup>1)</sup> "performance-optimised"	M	[Nm]		5,300 x (D - 80)
	Example for brake disk diameter D = 1000 mm			4876
Braking torque <sup>1)</sup> "noise-optimised"	M	[Nm]		4,370 x (D - 80)
	Example for brake disk diameter D = 1000 mm			4020
Nominal power			[W]	98
Brake disk	Outer diameter	D	[mm]	650 – 1500
	Width <sup>2)</sup>	K	[mm]	25
Brake	Bolt distance	A	[mm]	430
	Length	L	[mm]	198
	Height	H	[mm]	275
	Width	B	[mm]	475

- 1) Tolerance -0 % / +60 %  
 "performance-optimised" design:  
 For applications with high requirements on braking torque and performance density. Switching noises up to approx. 65 dB(A)  
 "noise-optimised" design:  
 For applications with high requirements on switching noises. Switching noises lower than 60 dB(A)
- 2) Other brake disk widths possible – **Please contact the respective sales representative or the mayr® company directly.**
- 3) Overexcitation is necessary for operation!

We reserve the right to make dimensional and constructional alterations.

**Certificate**

The brakes were prototype-inspected for their effect as a brake assembly on the drive sheave shaft and as part of the protective assembly against excessive upward-moving cage speeds. For a dual-circuit brake system acc. EN 81-1, at least two brakes are necessary.

**Certificate number:**  
**ABV 822 (Size 10)**

**Order Number**

Hand release		Release monitoring	
Hand release, Bowden cable	0	without	0
Hand release, actuated manually	1	with	1
▼			
10 / 8 9 4 . 2 1	— . —	3 / — / —	
▲	▲	▲	▲
Size 10	Type series	Connection cable	Coil voltage <sup>3)</sup>
	Basic Type series <u>without</u> alignment mechanism		104 [V DC]
	Type series <u>with</u> alignment mechanism		Deviating voltages on request
	0 5		

Example: 10 / 894.211.03 / 0 / 104 V DC

## Electrical Connection and Wiring

DC current is necessary for operation of the brake. The coil voltage is indicated on the Type tag as well as on the brake body and is designed according to the DIN IEC 60038 ( $\pm 10\%$  tolerance). Operation can take place via AC voltage in connection with a rectifier or with another suitable DC supply. The connection possibilities can vary dependent on the brake equipment. Please follow the exact connections according to the Wiring Diagram. The manufacturer and the user must observe the applicable directives and standards (e.g. DIN EN 60204-1 and DIN VDE 0580). Their observance must be guaranteed and double-checked!

### Earthing Connection

The brake is designed for Protection Class I. This protection covers not only the basic insulation, but also the connection of all conductive parts to the PE conductor on the fixed installation. If the basic insulation fails, no contact voltage will remain. Please carry out a standardized inspection of the PE conductor connections to all contactable metal parts.

### Device Fuses

To protect against damage from short circuits, please add suitable device fuses to the mains cable.

### Switching Behaviour

The operational behaviour of a brake is to a large extent dependent on the switching mode used. Furthermore, the switching times are influenced by the temperature and the air gap between the armature disk and the coil carrier (dependent on the wear condition of the linings).

### Magnetic Field Build-up

When the voltage is switched on, a magnetic field is built up in the brake coil, which attracts the armature disk to the coil carrier and releases the brake.

#### • Field Build-up with Normal Excitation

If the magnetic coil is energised with nominal voltage, the coil current does not immediately reach its nominal value. The coil inductivity causes the current to increase slowly as an exponential function. Accordingly, the build-up of the magnetic field takes place more slowly and the braking torque drop is also delayed (curve 1, see Fig. below).

#### • Field Build-up with Overexcitation

A quicker and safer drop in braking torque is achieved if the coil is temporarily placed under a higher voltage than the nominal voltage, as the current then increases more quickly. Once the brake is released, it needs to be switched over to the nominal voltage (curve 2, see Fig. below). The relationship between overexcitation and separation time  $t_2$  is roughly indirectly proportional, meaning that at overexcitation voltage  $U_{over}$  which equals double the nominal voltage  $U_{nom}$ , the separation time  $t_2$  for release of the brake is halved. The ROBA®-(multi)switch fast acting rectifier and phase demodulator work on this principle.

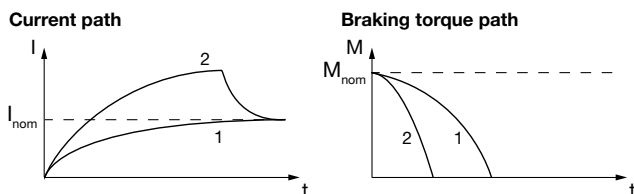

## Magnetic Field Removal

### • AC-side Switching

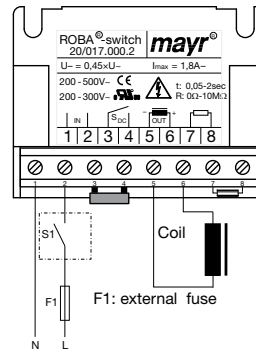

The power circuit is interrupted before the rectifier. The magnetic field slowly reduces. This delays the rise in braking torque.

When switching times are not important, please switch AC-side, as no protective measures are necessary for coil and switching contacts.

AC-side switching means **low-noise switching**; however, the brake engagement time is longer (approx. 6-10 times longer than with DC-side switching). Use for non-critical brake times.

### • DC-side Switching

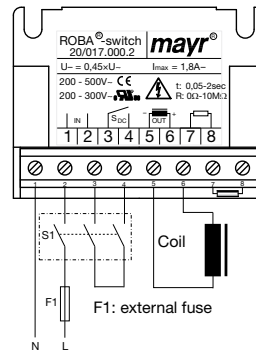

The power circuit is interrupted between the rectifier and the coil as well as mains-side. The magnetic field reduces extremely quickly. This causes a quick rise in braking torque.

When switching DC-side, high voltage peaks are produced in the coil, which lead to wear on the contacts from sparks and to destruction of the insulation.

DC-side switching means **short brake engagement times (e.g. for EMERGENCY STOP)**; however, louder switching noises.

### • Protective Circuit

When using DC-side switching, the coil must be protected by a suitable protective circuit according to VDE 0580, which is integrated in mayr® rectifiers. To protect the switching contact from consumption when using DC-side switching, additional protective measures are necessary (e.g. series connection of switching contacts). The switching contacts used should have a minimum contact opening of 3 mm and should be suitable for inductive load switching. Please make sure on selection that the rated voltage and the rated operation current are sufficient. Depending on the application, the switching contact can also be protected by other protective circuits (e.g. mayr®-spark quenching units), although this may of course then alter the switching times.



**Guidelines on the Declaration of Conformity:** A conformity evaluation has been carried out for the product (electromagnetic safety brake) acc. the EC Low Voltage Directive 2006/95/EC. The conformity evaluation is set out in writing in a separate document and can be requested if required.

**Guidelines on the EMC Directive (2004/108/EC):** The product cannot be operated independently according the EMC directive. Due to their passive state, brakes are also non-critical equipment acc. the EMC. Only after integration of the product into an overall system can this be evaluated in terms of the EMC. For electronic equipment, the evaluation has been verified for the individual product in laboratory conditions but not in the overall system.

**Guidelines on the Machinery Directive (2006/42/EC):** This product is a component for installation into machines acc. the Machinery Directive 2006/42/EC. The brakes are able to fulfil safety-orientated applications with relation to other elements. The type and scope of necessary measures result from a risk analysis of the machine. The brake is then part of the machine, and the machine manufacturer evaluates the conformity of the safety device according to the directive. It is forbidden to start use of the product until you have ensured that the machine accords with the specification laid down in the directive.

**Guidelines on the ATEX Directive:** Without a conformity evaluation, this product is not suitable for use in areas where there is a high danger of explosion. Classification and marking acc. directive 94/9/EC must be carried out if this product is to be used in areas where there is a danger of explosion.

**Safety Guidelines**

Brakes may generate the following risks, among other things:



During the required risk assessment when designing the machine or system, the dangers involved must be evaluated and removed by taking appropriate protective measures. **To prevent injury or damage, only professionals and specialists should work on the devices.** They must be familiar with the dimensioning, transport, installation, initial operation, maintenance and disposal according to the relevant standards and regulations.

**Application Conditions**



The catalogue values are guideline values which have been determined in test facilities. It may be necessary to carry out your own tests for the intended application.

When dimensioning the brakes, please remember that installation situations, braking torque fluctuations, permitted friction work, run-in behaviour and wear as well as general ambient conditions can all affect the given values. These factors should therefore be carefully assessed, and alignments made accordingly.

- Mounting dimensions and connecting dimensions must be adjusted according to the size of the brake at the place of installation.
- The magnetic coils are designed for a relative duty cycle of 100 %, if no deviating values are stated.
- The braking torque is dependent on the present run-in condition of the brakes.
- The brakes are only designed for dry running. The torque is lost if the friction surfaces come into contact with oil, grease, water or similar substances, such as other foreign substances.
- Manufacturer-side corrosion protection of the metal surfaces.
- The rotors may rust up and block in corrosive ambient conditions and/or after long periods of storage.

**Earthing Connection**

The brake is designed for Protection Class I. This protection covers not only the basic insulation, but also the connection of all conductive parts to the PE conductor on the fixed installation. If the basic insulation fails, no contact voltage will remain. Please carry out a standardized inspection of the PE conductor connections to all contactable metal parts.

**Protection**

**(Mechanical) IP12:** Protection against large body surfaces and large foreign bodies > 50 mm in diameter. Protected against dripping water, if the housing is inclined up to 15°.

**(Electrical) IP54:** Dust-proof and protected against contact as well as against water spray from all directions.

**Ambient Temperature:**

- 10 °C to + 45 °C

**Appointed Use**

mayr®-brakes have been developed, manufactured and tested in compliance with the VDE 0580 standard, in accordance with the EU Low Voltage Directive. During installation, operation and maintenance of the product, the standard requirements must be observed. mayr®-brakes are for use in machines and systems and must only be used in the situations for which they are ordered and confirmed. Using them for any other purpose is not allowed.

**Guidelines for Electromagnetic Compatibility (EMC)**

In accordance with the EMC directive 2004/108/EC, the individual components produce no emissions. However, functional components e.g. mains-side energisation of the brakes with rectifiers, phase demodulators, ROBA®-switch devices or similar controls can produce disturbance which lies above the allowed limit values. For this reason, please read the Installation and Operational Instructions carefully and ensure that the EMC directives are maintained.

**Regulations, Standards and Directives Used**

VDE 0580	Electromagnetic devices and components, general directives
2006/95/EC	Low voltage directive
95/16/EC	Elevator directive
EN 81-1	Safety regulations for the construction and installation of elevators and small goods elevators
CSA C22.2 No. 14-2010	Industrial Control Equipment
UL 508 (Edition 17)	Industrial Control Equipment

**Please observe the following standards:**

EN ISO 12100-1 and 2	Machine safety
EN ISO 14121-1	Risk assessment
EN 61000-6-4	Noise emission
EN 12016	Interference resistance (for elevators, escalators and moving walkways)
EN 60204-1	Electrical machine equipment

**Liability**

- The information, guidelines and technical data in these documents were up to date at the time of printing. Demands on previously delivered brakes are not valid.
- Liability for damage and operational malfunction will not be taken if:
  - the Installation and Operational Instructions are ignored or neglected,
  - the brakes are used inappropriately,
  - the brakes are modified,
  - the brakes are worked on unprofessionally,
  - the brakes are handled or operated incorrectly.

**Guarantee**

- The guarantee conditions correspond with the Chr. Mayr GmbH + Co. KG sales and delivery conditions.
- Mistakes or deficiencies are to be reported to mayr® at once.





## Headquarters

**Chr. Mayr GmbH + Co. KG**  
**Eichenstrasse 1, D-87665 Mauerstetten**  
**Tel.: 0 83 41/8 04-0, Fax: 0 83 41/80 44 21**  
**www.mayr.de, E-Mail: info@mayr.de**



**mayr**<sup>®</sup>

## Service Germany

### Baden-Württemberg

Esslinger Straße 7  
 70771 Leinfelden-Echterdingen  
 Tel.: 07 11/45 96 01 0  
 Fax: 07 11/45 96 01 10

### Bavaria

Eichenstrasse 1  
 87665 Mauerstetten  
 Tel.: 0 83 41/80 41 04  
 Fax: 0 83 41/80 44 23

### Chemnitz

Bornaer Straße 205  
 09114 Chemnitz  
 Tel.: 03 71/4 74 18 96  
 Fax: 03 71/4 74 18 95

### Franken

Unterer Markt 9  
 91217 Hersbruck  
 Tel.: 0 91 51/81 48 64  
 Fax: 0 91 51/81 62 45

### Hagen

Im Langenstück 6  
 58093 Hagen  
 Tel.: 0 23 31/78 03 0  
 Fax: 0 23 31/78 03 25

### Kamen

Lünener Strasse 211  
 59174 Kamen  
 Tel.: 0 23 07/23 63 85  
 Fax: 0 23 07/24 26 74

### North

Schiefer Brink 8  
 32160 Extertal  
 Tel.: 0 57 54/9 20 77  
 Fax: 0 57 54/9 20 78

### Rhine-Main

Jägerstrasse 4  
 64739 Höchst  
 Tel.: 0 61 63/48 88  
 Fax: 0 61 63/46 47

## Branch office

### China

Mayr Zhangjiagang  
 Power Transmission Co., Ltd.  
 Changxing Road No. 16,  
 215600 Zhangjiagang  
 Tel.: 05 12/58 91-75 65  
 Fax: 05 12/58 91-75 66  
 info@mayr-ptc.cn

### Great Britain

Mayr Transmissions Ltd.  
 Valley Road, Business Park  
 Keighley, BD21 4LZ  
 West Yorkshire  
 Tel.: 0 15 35/66 39 00  
 Fax: 0 15 35/66 32 61  
 sales@mayr.co.uk

### France

Mayr France S.A.  
 Z.A.L. du Minopole  
 BP 16  
 62160 Bully-Les-Mines  
 Tel.: 03.21.72.91.91  
 Fax: 03.21.29.71.77  
 contact@mayr.fr

### Italy

Mayr Italia S.r.l.  
 Viale Veneto, 3  
 35020 Saonara (PD)  
 Tel.: 0 49/8 79 10 20  
 Fax: 0 49/8 79 10 22  
 info@mayr-italia.it

### Singapore

Mayr Transmission (S) PTE Ltd.  
 No. 8 Boon Lay Way Unit 03-06,  
 TradeHub 21  
 Singapore 609964  
 Tel.: 00 65/65 60 12 30  
 Fax: 00 65/65 60 10 00  
 info@mayr.com.sg

### Switzerland

Mayr Kupplungen AG  
 Tobeläckerstrasse 11  
 8212 Neuhausen am Rheinfall  
 Tel.: 0 52/6 74 08 70  
 Fax: 0 52/6 74 08 75  
 info@mayr.ch

### USA

Mayr Corporation  
 4 North Street  
 Waldwick  
 NJ 07463  
 Tel.: 2 01/4 45-72 10  
 Fax: 2 01/4 45-80 19  
 info@mayrcorp.com

## Representatives

### Australia

Transmission Australia Pty. Ltd.  
 22 Corporate Ave,  
 3178 Rowville, Victoria  
 Australien  
 Tel.: 0 39/7 55 44 44  
 Fax: 0 39/7 55 44 11  
 info@transaus.com.au

### China

Mayr Power Transmission Co., Ltd.  
 Shanghai Representative Office  
 Room 2206, No. 888 Yishan Road  
 200233 Shanghai, VR China  
 Tel.: 0 21/64 32 01 60  
 Fax: 0 21/64 57 56 21  
 Trump.feng@mayr.de

### India

National Engineering  
 Company (NENCO)  
 J-225, M.I.D.C.  
 Bhosari Pune 411026  
 Tel.: 0 20/27 47 45 29  
 Fax: 0 20/27 47 02 29  
 nenco@nenco.org

### Japan

MATSUI Corporation  
 2-4-7 Azabudai  
 Minato-ku  
 Tokyo 106-8641  
 Tel.: 03/35 86-41 41  
 Fax: 03/32 24 24 10  
 k.goto@matsui-corp.co.jp

### South Africa

Torque Transfer  
 Private Bag 9  
 Elandsfontein 1406  
 Tel.: 0 11/3 45 80 00  
 Fax: 0 11/9 74 05 24  
 torque@bearings.co.za

### South Korea

Mayr Korea Co. Ltd.  
 Room No.1002, 10th floor,  
 Nex Zone, SK TECHNOPARK,  
 77-1, SungSan-Dong,  
 SungSan-Gu, Changwon, Korea  
 Tel.: 0 55/2 62-40 24  
 Fax: 0 55/2 62-40 25  
 info@mayrkorea.com

### Taiwan

German Tech Auto Co., Ltd.  
 No. 162, Hsin sheng Road,  
 Taishan Hsiang,  
 Taipei County 243, Taiwan R.O.C.  
 Tel.: 02/29 03 09 39  
 Fax: 02/29 03 06 36  
 steve@zfgta.com.tw

### Machine tools

Applications in China  
 Dynamic Power Transmission Co., Ltd.  
 Block 5th, No. 1699, Songze Road,  
 Xujing Industrial Zone  
 201702 Shanghai, China  
 Tel.: 021/59883978  
 Fax: 021/59883979  
 dtcshanghai@online.sh.cn

### More representatives:

Austria, Benelux States, Brazil, Canada, Czech Republic, Denmark, Finland, Greece, Hongkong, Hungary, Indonesia, Israel, Malaysia, New Zealand, Norway, Philippines, Poland, Romania, Russia, Slovakia, Slovenia, Spain, Sweden, Thailand, Turkey

**You can find the complete address for the representative responsible for your area under [www.mayr.de](http://www.mayr.de) in the internet.**

**mayr**<sup>®</sup>  
 your reliable partner

## Sicherheitskupplungen/Überlastkupplungen

- ❑ **EAS®-compact®/EAS®-NC**  
Formschlüssige und absolut spielfreie Sicherheitskupplungen
- ❑ **EAS®-smartic®**  
Kostengünstige Sicherheitskupplungen mit Schnellmontage
- ❑ **EAS®-Elementekupplung/EAS®-Elemente**  
Lasttrennende Absicherung von hohen Drehmomenten
- ❑ **EAS®-axial**  
Exakte Begrenzung von Zug- und Druckkräften
- ❑ **EAS®-Sp/EAS®-Sm/EAS®-Zr**  
Restmomentfrei trennende Sicherheitskupplungen mit Schaltfunktion
- ❑ **ROBA®-Rutschnaben**  
Lasthaltende, reibschlüssige Sicherheitskupplungen
- ❑ **ROBA®-contitorque**  
Magnetische Dauerschlupfkupplungen



## Wellenkupplungen

- ❑ **smartflex®**  
Perfekte Präzisionskupplungen für Servo- und Schrittmotoren
- ❑ **ROBA®-ES**  
Spielfrei und dämpfend für schwingungskritische Antriebe
- ❑ **ROBA®-DS/ROBA®-D**  
Spielfreie, drehsteife Ganzstahlkupplungen
- ❑ **EAS®-control-DS**  
Kostengünstige Drehmoment-Messkupplungen

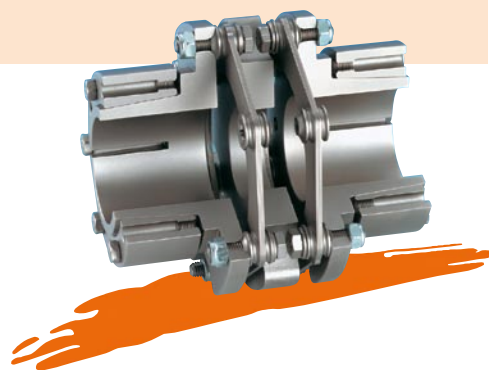

## Elektromagnetische Bremsen/Kupplungen

- ❑ **ROBA-stop® Standard**  
Multifunktionale Allround-Sicherheitsbremsen
- ❑ **ROBA-stop®-M Motorbremsen**  
Robuste, kostengünstige Motorbremsen
- ❑ **ROBA-stop®-S**  
Wasserdichte, robuste Monoblockbremsen
- ❑ **ROBA-stop®-Z/ROBA-stop®-silenzio®**  
Doppelt sichere Aufzugsbremsen
- ❑ **ROBA®-diskstop®**  
Kompakte, flüsterleise Scheibenbremsen
- ❑ **ROBA®-topstop®**  
Bremsysteme für schwerkraftbelastete Achsen
- ❑ **ROBA®-linearstop**  
Spielfreie Bremsysteme für Linearmotorachsen
- ❑ **ROBATIC®/ROBA®-quick/ROBA®-takt**  
Arbeitsstromkupplungen und -bremsen, Kupplungsbremsaggregate



## Gleichstromantriebe

- ❑ **tendo®-PM**  
Permanentmagneterregte Gleichstrommotoren
- ❑ **tendo®-SC**  
1- und 4 Quadranten-Transistorregler

