

Safety Brake in Accordance with the Machinery Directive

ROBA[®]-linearstop
Type 381.0 __.__. / 381.1 __.__.
Sizes 20 – 80

Version 1.0

Issue status 2013-10

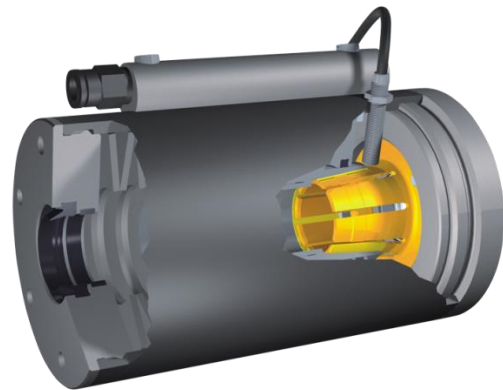

Translation of the Original Operational Instructions B.381.1.EN

© Copyright by *mayr*[®] – power transmission

All rights reserved.

Reprints and copies – even extracts – are only permitted with the consent of the manufacturer.

Contents

1 General Guidelines.....	3	7.1.1 Functional Safety Guidelines	16
1.1 Definition of Terms.....	3	7.1.2 Condition	16
2 Safety 4		8 Storage	16
2.1 Safety and Guideline Signs.....	4	8.1 Brake Storage.....	16
2.2 General Guidelines	4	9 Installation	17
2.2.1 Personnel Requirements	4	9.1 Installation Conditions	17
2.3 Appointed Use	5	9.1.1 General	17
2.4 Handling.....	5	9.1.2 Piston Rod	17
2.5 User-implemented Protective Measures	5	9.1.3 Controls	18
2.6 Dimensioning Other Machine Elements	5	9.2 Installation (Figs. 1 and 2)	19
3 Legal Provisions.....	6	9.2.1 Pre-requisites	19
3.1 Standards, Directives and Regulations Used...	6	9.2.2 Preparation	19
3.2 Liability	6	9.2.3 Installation Procedure	19
3.3 Guarantee	6	9.3 Compressed air connection.....	19
3.4 Guidelines on CE Identification	7	10 Options	20
3.5 CE-Identification Type 381.1_ _ _	7	10.1 Switching condition monitoring (NO contact)....	20
3.6 Certification Symbols Type 381.1_ _ _	7	10.2 Wear Monitoring	21
3.7 Identification/ Type tag	8	10.3 Adaptor for Standard Cylinder acc. ISO 15552.22	22
4 Product Description	9	10.3.1 Dimensions Sheet	22
4.1 Scope of Delivery / State of Delivery.....	9	11 Initial Operation / Operation.....	23
4.2 Function	9	11.1 Brake Inspection (Before Initial Operation).....	23
4.3 Views	10	11.2 Brake Test (initial operation).....	23
4.4 Parts List.....	10	11.2.1 (Static) Brake Inspection	23
5 Technical Data	11	11.2.2 (Dynamic) Brake Test	23
5.1 Guidelines	11	11.3 Brake Inspection (during operation).....	23
5.1.1 Application Conditions	11	11.3.1 Regular Function Inspection (static)	23
5.1.2 Ambient Temperature	11	11.3.2 Regular Functional Inspection (dynamic)	23
5.1.3 Protection	11	12 Maintenance / Inspection / Switching Frequency	24
5.1.4 Noise Emissions	11	
5.1.5 Installation Position	11	12.1 Switching Frequency	24
5.1.6 Pre-requisites for Product Application	11	12.2 Inspection	24
5.2 Technical Data	12	12.3 Maintenance	24
5.3 Dimensions Sheet.....	12	12.4 Cleaning:	25
6 Intended Use.....	13	13 De-installation	25
6.1 Guidelines for Application	13	14 Disposal.....	25
6.2 Limits.....	13	15 Malfunctions / Breakdowns.....	26
6.3 Reasonably Foreseeable Misuse	13	16 Declaration of Conformity.....	27
6.4 Duration of Use	13		
6.5 Braking Distance (Brake Unit Type 381.1_ _ _) .	14		
6.5.1 Calculation of the Braking Distance	14		
6.5.2 Calculation Example: Dynamic Brake Type 381.1_ _ _	15		
7 Functional Safety Parameters	16		

Please read these Operational Instructions carefully and follow them accordingly!

Ignoring these Instructions may lead to malfunctions or to brake failure, resulting in damage to other parts. These Operational Instructions are part of the brake delivery.
Please keep them handy and near to the brake at all times.





1 General Guidelines

1.1 Definition of Terms

Term	Meaning
ROBA [®] -linearstop	Pneumatically-actuated piston rod brake as a component for holding and deceleration of moved machine parts.
Nominal holding force F_{Nenn}	The theoretical nominal holding force assigned to the designation. The nominal holding force lies within the stated nominal holding force tolerances.
Load mass	Nominal holding force which is required to hold a vertical axis (load) suspended, referring to the brake.

2 Safety

2.1 Safety and Guideline Signs

Symbol	Signal word	Meaning
	DANGER	Designates a directly pending danger. If not avoided, death or severe injuries will be the consequence.
	WARNING	Designates a possibly hazardous situation. If not avoided, death or severe injuries will be the consequence.
	CAUTION	Designates a hazardous situation. If not avoided, slight or minor injuries can be the consequence.
	ATTENTION	Possible property damage can be the consequence.
	Please Observe	Designates tips for application and other particularly useful information. Not a signal word for dangerous or damaging situations.

2.2 General Guidelines

Brakes may generate several risks, among others:



Severe injury to people and damage to objects may result if:

- the brake is used incorrectly.
- the brake is modified.
- the relevant standards for safety and / or installation conditions are ignored.

During the risk assessment required when designing the machine or system, the dangers involved must be evaluated and removed by taking appropriate protective measures.

2.2.1 Personnel Requirements

To prevent injury or damage, only professionals and specialists are allowed to work on the devices. They must be familiar with the dimensioning, transport, installation, initial operation, maintenance and disposal according to the relevant standards and regulations.



Before product installation and initial operation, please read the Installation and Operational Instructions carefully and observe the Safety Regulations. Incorrect operation can cause injury or damage.

At the time these Installation and Operational Instructions go to print, the pneumatic brakes accord with the known technical specifications and are operationally safe at the time of delivery.

- Technical data and specifications (Type tags and documentation) must be followed.

General Guideline:

During the risk assessment required when designing the machine or system, the dangers involved must be evaluated and removed by taking appropriate protective measures in accordance with the Machinery Directive 2006/42/EC.

Brakes for safety-related applications are to be installed singly or as redundant devices in accordance with the required category, in order to fulfil the required Performance Level (PL_r) acc. EN ISO 13849. This is in principle the task of the system manufacturer.

2.3 Appointed Use



Use according to the intended purpose is prohibited until it has been determined that the machine / system accords with the EC Directive 2006/42/EC (machinery directive).

mayr[®]-brakes are for use in machines and systems and must only be used in the situations for which they are ordered and confirmed. Using them for any other purpose is not allowed.

ROBA[®]-linearstop brakes by *mayr*[®] are used for holding and deceleration of piston rods.

2.4 Handling

Before installation, the brake must be inspected and found to be in proper condition. The following are not considered as being representative of a proper condition:

- Outer damage
- Outer oiling
- Outer contamination

The brake function must be inspected both **once attachment has taken place** as well as **after longer system downtimes**, in order to prevent the drive starting up against possibly seized linings.

2.5 User-implemented Protective Measures

- Please cover moving parts to protect **against injury through seizure**.
- Install additional protective measures **against corrosion** if the brake is subject to extreme ambient conditions or is installed in open air conditions, unprotected from the weather.

2.6 Dimensioning Other Machine Elements



The effects of the maximum and minimum braking force on the other machine components must be observed in order to provide sufficient dimensioning. The ROBA[®]-linearstop has (at room temperature) a maximum braking force of 2,5 x brake nominal holding force and a minimum braking force of 1 x brake nominal holding force.

If other brakes are positioned behind the ROBA[®]-linearstop, and if the braking times of the different brakes overlap, the loads will add up.

3 Legal Provisions

3.1 Standards, Directives and Regulations Used

(also to be observed during installation and operation)

2006/42/EC	Machinery directive
EN ISO 4414	General rules and safety requirements for pneumatic systems and their components
EN ISO 12100	Safety of machinery - General principles for design - Risk assessment and risk reduction
EN ISO 13849-1	Safety of machinery – Safety related parts of control systems

3.2 Liability

The information, guidelines and technical data in these documents were up to date at the time of printing. Demands on previously delivered brakes are not valid. Liability for damage and operational malfunctions will not be taken if:

- the Installation and Operational Instructions are ignored or neglected.
- the brakes are used inappropriately.
- the brakes are modified.
- the brakes are worked on unprofessionally.
- the brakes are handled or operated incorrectly.

3.3 Guarantee

- The guarantee conditions correspond with the Chr. Mayr GmbH + Co. KG sales and delivery conditions (www.mayr.com → Service → General Terms and Conditions)
- Mistakes or deficiencies are to be reported to *mayr*[®] at once!

3.4 Guidelines on CE Identification



Guidelines on the Machinery Directive (2006/42/EC)

The product is a component for installation into machines according to the Machinery Directive 2006/42/EC. The component represents a safety component in accordance with Art 2(c) in terms of the machinery directive.

The brakes can fulfil the specifications for safety-related applications in coordination with other elements (control, wiring).

The type and scope of the required measures result from the machine risk assessment. The brake then becomes a machine component and the machine manufacturer assesses the conformity of the safety device to the directive.

A risk assessment and a conformity evaluation have been carried out for the component (pneumatic clamping and braking system) in terms of the Machinery Directive 2006/42/EC.

Guidelines on the ATEX Directive

Without a conformity evaluation, this product is not suitable for use in areas where there is a high danger of explosion.

For application of this product in areas where there is a high danger of explosion, it must be classified and marked according to directive 94/9/EC.

3.5 CE-Identification Type 381.1 _ _ _



Identification according to the Machinery Directive 2006/42/EC

3.6 Certification Symbols Type 381.1 _ _ _



TÜV (German Technical Inspectorate) test certificate:

The pneumatic linear brake complies - when used according to the intended use, for the application range stated in the appendix (pages 1-2) of this certification (No. KP 136), observing the stated conditions - with the requirements stated in the testing specifications.

Operational Instructions for ROBA®-linearstop Type 381. _ _ _ _ Sizes 20 – 80

(B.381.1.EN)

3.7 Identification/ Type tag

mayr® components are clearly marked and described on the Type tag:

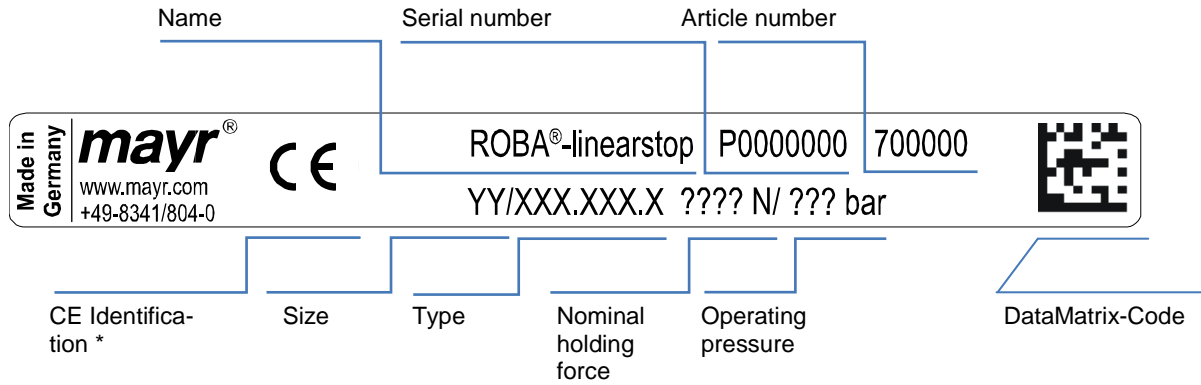

*) only for Type 381.1_ _ _ _

Serial number

Year	Code
2000	A
2001	B
2002	C
2003	D
2004	E
2005	F
2006	H
2007	J
2008	K
2009	L
2010	M
2011	N

Year	Code
2012	P
2013	R
2014	S
2015	T
2016	U
2017	V
2018	W
2019	X
2020	A

Operational Instructions for ROBA[®]-linearstop Type 381._____ Sizes 20 – 80

(B.381.1.EN)

4 Product Description

4.1 Scope of Delivery / State of Delivery

- ❑ ROBA[®]-linearstop brake Types 381.0____ and 381.1____ are manufacturer-assembled and ready for installation.
- ❑ The ROBA[®]-linearstop is set to the nominal holding force stipulated in the order.
- ❑ Please observe the Type tag.

Please check the state of delivery immediately!
Mayr[®] will take no responsibility for belated complaints.
Please report transport damage immediately to the deliverer. Please report incomplete delivery and obvious defects to the manufacturer.



CAUTION Please observe the own weight of the brake

The brake may drop during lifting / transport.

This might lead to crushing or bruising, e.g. of the foot.

4.2 Function

The spring-loaded, enclosed **ROBA[®]-linearstop** (Type 381.0____), which can be opened pneumatically, clamps a piston rod steplessly and backlash-free.

The **ROBA[®]-linearstop** (Type 381.1____) clamps **and brakes** a piston rod steplessly and backlash-free.



Please Observe!

The maximum clamping force can only be reached when the brake is pressureless.

Due to the spring-loaded system, the fail-safe principle can be guaranteed, the **ROBA[®]-linearstop** works as a **safety brake**.

The required operating pressure is stated on the Type tag.



Please Observe!

If the operating pressure is too low, the brake cannot be aerated sufficiently.

- ❑ By aerating the **ROBA[®]-linearstop** with the required operating pressure, the clamping element of the brake is pressed against the spring. The piston rod can be moved (Illustration 1).
- ❑ By de-aerating the **ROBA[®]-linearstop**, the spring has an effect on the clamping element of the brake. The piston rod is clamped (Fig. 2).

The max. permitted sliding speed is 2 m/s.

Higher speeds on request! Höhere speed available on request!



Please Observe!

Before brake release, the collet must enclose the piston rod completely.

If the piston rod ends in the collet, the clamping element might get damaged when actuating the brake!

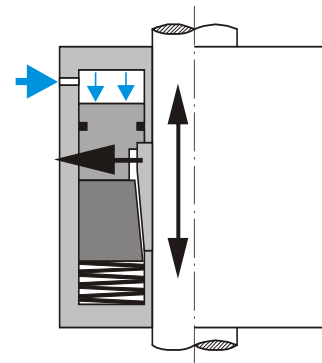

Illustration 1 Moveable piston rod on pressurization

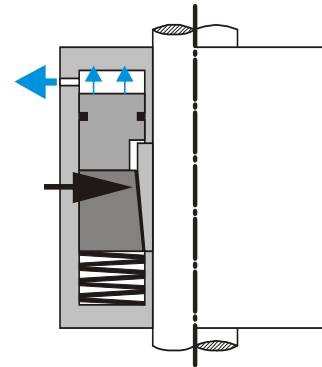

Illustration 2 Clamped piston rod on pressure release

4.3 Views

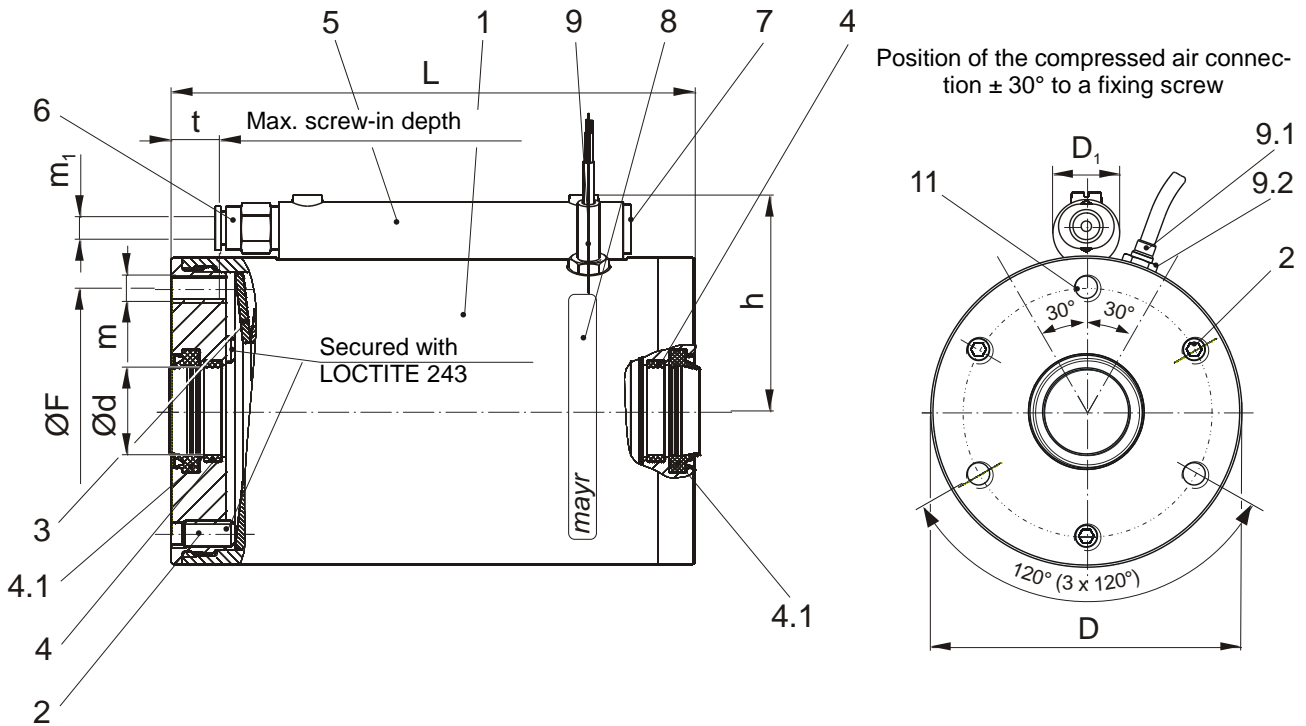

Fig. 1

Fig. 2

4.4 Parts List

(Only use *mayr*® original parts)

Item	Name
1	Housing
2	Set screw
3	Spring
4	Guide ring
4.1	Wiper
5	Compressed air connection
6	Plug-in fitting for connection thread, see section 5.2
7	Screw plug
8	Type tag
9	Switching condition monitoring (option dependent on Type)
9.1	Proximity switch
9.2	Hexagon nut
10	Wear monitoring (option dependent on Type) - not depicted (equals Item 9)
11	Threaded holes for fixing screws (m)

5 Technical Data

5.1 Guidelines

5.1.1 Application Conditions



The stated values are guideline values which have been determined in test facilities. It may be necessary to carry out your own tests for the intended application.

When dimensioning the brakes, please remember that installation situations, permitted friction work and braking distances as well as general ambient conditions can all affect the given values.

- These factors should therefore be carefully assessed, and alignments made accordingly.
- Mounting dimensions and connecting dimensions must be adjusted according to the size of the brake at the place of installation.
- The surfaces of the outer components have been phosphated manufacturer-side to form a basic corrosion protection.
- The provision of the required operating pressure must be guaranteed.

5.1.2 Ambient Temperature

-10 °C up to +70 °C, non-condensing

5.1.3 Protection

(mechanical) IP54: When installed, dust-proof and protected against contact as well as against water spray from any direction (dependent on customer-side mounting method).

5.1.4 Noise Emissions

Normally no noise development

5.1.5 Installation Position

The ROBA[®]-linearstop can be operated in any installation position.

5.1.6 Pre-requisites for Product Application

Compare the limit values stated in these Installation and Operational Instructions with the actual application, e.g.

- Pressure
- Clamping / braking forces
- Braking distance
- Masses
- Temperatures etc.

Operational Instructions for ROBA[®]-linearstop Type 381. _ _ _ _ Sizes 20 – 80

(B.381.1.EN)

5.2 Technical Data

				Size					
				20	30	40	60	70	80
Nominal holding force ¹⁾²⁾ (minimum holding force)	Type 381._ 0_ . _	F _{Nenn}	[kN]	0,45 – 0,7	0,8 – 1,3	1,5 – 2,5	4,6 – 7,5	7,5 – 12,0	12,5 – 21,0
	Type 381._ 1_ . _			0,62 – 0,97	1,1 – 1,75	2,1 – 3,4	6,3 – 10,5	10,0 – 16,7	17,5 – 30,0
	Type 381._ 2_ . _			0,75 – 1,2	1,4 – 2,2	2,65 – 4,4	8,2 – 13,8	13,0 – 22,5	23,0 – 40,0
Operating pressure			[bar]	See Type tag (4,0 – 6,0)					
Max. operating pressure			[bar]	8					
Weight	Type 381._ 0_ . _		[kg]	0,8	1,2	2	6	10,5	19
	Type 381._ 1_ . _			0,9	1,4	2,3	6,6	11,5	21
	Type 381._ 2_ . _			1,0	1,5	2,5	7,1	12,5	23
Absorption volume	Type 381._ 0_ . _		[cm ³]	3,6	7	14	41	65	108
	Type 381._ 1_ . _			5	9	19	54	87	143
	Type 381._ 2_ . _			6	12	23	68	108	179
Plug-in fitting	Tube outer diameter	m ₁	[mm]	6	6	8	10	10	12
	Connection thread			M5	M5	G1/8 (SW4)	G1/4 (SW6)	G3/8 (SW8)	G3/8 (SW8)
	Tightening torque		[Nm]	1,5	1,5	10	15	25	25
Proximity switch Hexagon nut Item 9.2:	Tightening torque		[Nm]	2	2	2	2	4	4
	Thread			M5 (SW8)	M5 (SW8)	M5 (SW8)	M5 (SW8)	M6 (SW10)	M6 (SW10)
Pressure medium				Compressed air VG-32 ISO 3448 filtered, oiled or not oiled					

¹⁾ Type 381.0 Nominal holding force when the brake is not pressurized, and with the piston rod dry or moistened with mineral oil.

²⁾ Type 381.1 Nominal holding force when the brake is not pressurized, and with a dry piston rod.

5.3 Dimensions Sheet

[mm]		Size					
		20	30	40	60	70	80
d		16	20	20	25	32	40
D		46	56	70	110	140	178
D1		15	15	18	20	24	24
F		34	44	56	90	112	142
h		37,3	42,3	52,8	75,9	94,4	113,9
L	Type 381._ 0_ . _	108	114,5	119,5	140,5	161	187
	Type 381._ 1_ . _	126,7	133,7	138,7	162,5	187	216,8
	Type 381._ 2_ . _	145,7	152,9	157,9	184,5	213	246,6
m		3xM5	3xM6	3xM6	3xM8	3xM10	3xM12
t		13,5	12,5	12,5	13,5	13,5	16,5

6 Intended Use

6.1 Guidelines for Application

- Please observe the correct dimensioning of clamping or braking force, friction work and switching frequency at an EMERGENCY STOP for safe holding of the mass and safe compliance of the required brake path.
- Static application
(clamping unit) Type 381.0_ _ _
 - Holding and clamping in case of power failure
 - In case of pressure drop
 - EMERGENCY STOP
- Dynamic application
(brake unit) Type 381.1_ _ _
 - Holding and clamping in case of power failure
 - In case of pressure drop
 - EMERGENCY STOP
 - Braking/stopping of linear movements
- Application in clean environments (penetration of coarse dust and liquids such as oils can have a negative effect on the clamping / braking function).
- Application in enclosed buildings (in tropical regions, in high humidity and temperatures below 0 °C with long downtimes, and sea climates only after taking special measures).

Please contact the *mayr*[®] place of manufacture.



Brakes which are to be used in safety-related applications must be selected, dimensioned and positioned according to the risk assessment DIN EN 12100 and other standards and regulations applicable to the special application. This is in principle the task of the system manufacturer/user.

6.2 Limits

- The brake is not suitable for use in oily or severely contaminated environments
- The brake is not suitable for application in high ambient temperatures >70 °C

6.3 Reasonably Foreseeable Misuse

- Brake is used in oily or heavily contaminated surroundings

6.4 Duration of Use

20 years or on reaching the T10d (for definition, see EN ISO 13849-1) duration of use.

6.5 Braking Distance (Brake Unit Type 381.1____)

Pre-selection

Dynamic braking actions / EMERGENCY STOP

$$F_{\text{erf.}} = \frac{m \times g}{0,5} \quad [\text{N}]$$

Clamping (without EMERGENCY STOP)

$$F_{\text{erf.}} = \frac{m \times g}{0,8} \quad [\text{N}]$$

$$F_{\text{Nenn}} \geq F_{\text{erf.}} \quad [\text{N}]$$

6.5.1 Calculation of the Braking Distance

Dynamic braking actions / EMERGENCY STOP for vertical axis 90°

Specifications

$$t_{\text{Ventil}} = \text{approx. } 0,016 \text{ s} \quad [\text{s}]$$

$$t_{50} = \text{See section 6.5.2.3 table friction work and switching times} \quad [\text{s}]$$

System distance (distance up to start of retardation)

$$S_{\text{Sys}} = V_0 \times t_{\text{Sys}} + g \times t_{\text{Sys}}^2 \times 0,5 \quad [\text{m}]$$

$$t_{\text{Sys}} = t_{50} + t_{\text{Ventil}} \quad [\text{s}]$$

Braking distance (distance from start of retardation)

$$S_{\text{Br}} = \frac{V_{\text{max}}^2}{2 \times \left(\frac{F_{\text{Br}}}{m} - g \right)} \quad [\text{m}]$$

$$V_{\text{max}} = V_0 + g \times t_{\text{Sys}} \quad [\text{m/s}]$$

$$F_{\text{Br}} = \frac{m \times g}{2} + \frac{F_{\text{Nenn}}}{2} \quad [\text{N}]$$

Stopping distance

$$S_{\text{Ko}} = S_{\text{Br}} + S_{\text{Sys}} \quad [\text{m}]$$

Stopping time

$$t_{\text{Ko}} = t_{\text{Br}} + t_{\text{Sys}} \quad [\text{s}]$$

$$t_{\text{Br}} = \frac{V_{\text{max}}}{\frac{F_{\text{Br}}}{m} - g} \quad [\text{s}]$$

Friction Work

Friction work per braking action

$$Q_r = m \times g \times S_{\text{Br}} + 0,5 \times m \times V_{\text{max}}^2 \quad [\text{J}]$$

Number of braking actions up to wear end

$$Z_{\text{zul.}} = \frac{Q_{r \text{ ges}}}{Q_r}$$

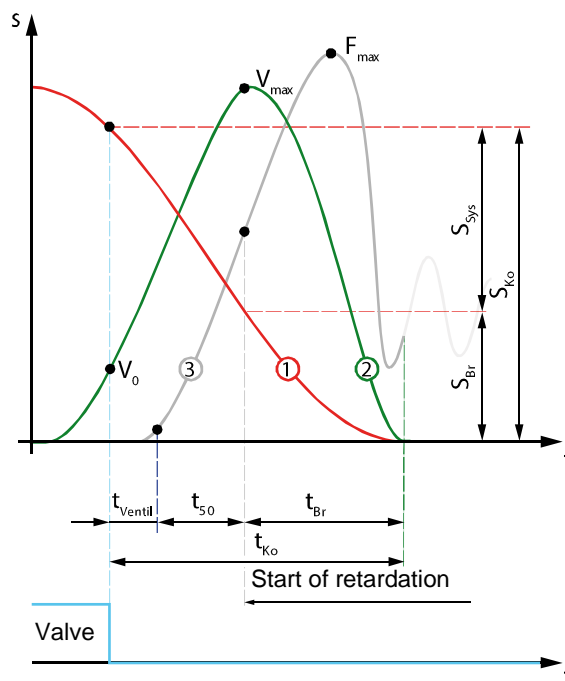

Diagram: Switching / Braking Times / Distances

1		Distance
2		Speed
3		Axial force
a	[m/s ²]	Retardation
g	[m/s ²]	Gravitational acceleration (9,81 m/s ²)
F _{Br}	[N]	Braking force for dynamic calculation
F _{erf.}	[N]	Required holding force
F _{Nenn}	[N]	Nominal holding force (minimum holding)
F _{max}	[N]	Maximum holding force
m	[kg]	Load mass
S _{Br}	[m]	Braking distance (distance from start of
S _{Sys}	[m]	System distance (distance up to start of
S _{Ko}	[m]	Stopping distance
t ₅₀	[s]	Brake switching time
t _{Ventil}	[s]	Valve switching time
t _{sys}	[s]	System switching time
t _{Br}	[s]	Brake braking time
t _{Ko}	[s]	Stopping time
Q _r	[J]	Friction work per braking action
Q _{r zul.}	[J]	Permitted friction work per braking action
Q _{r ges}	[J]	Total friction work up to wear end
V ₀	[m/s]	Initial speed
V _{max}	[m/s]	Maximum speed
Z _{zul.}		Number of braking actions up to wear end

If you have any questions, please contact **mayr®**.

Operational Instructions for ROBA®-linearstop Type 381.1___. Sizes 20 – 80

(B.381.1.EN)

6.5.2 Calculation Example: Dynamic Brake Type 381.1___.

Data			
Vertical axis			
Speed	g	= 9,81 m/s ²	
Initial speed	V ₀	= 0,5 m/s	
Mass	m	= 800 kg	
Existing operating pressure		= 5 bar	

$$V_{\max} = V_0 + g \times t_{\text{Sys}} \quad [\text{m/s}]$$

$$V_{\max} = 0,5 + 9,81 \times 0,076 = 1,25 \quad [\text{m/s}]$$

$$F_{\text{Br}} = \frac{m \times g}{2} + \frac{F_{\text{Nenn}}}{2} \quad [\text{N}]$$

$$F_{\text{Br}} = \frac{800 \times 9,81}{2} + \frac{17500}{2} = 12674 \quad [\text{N}]$$

6.5.2.1 Pre-selection of Braking Force

$$F_{\text{erf.}} = \frac{m \times g}{0,5} \quad [\text{N}]$$

$$F_{\text{erf.}} = \frac{800 \times 9,81}{0,5} = 15696 \quad [\text{N}]$$

Selected: ROBA®-linearstop Size 70, Type 381.12___.
Nominal holding force $F_{\text{Nenn}} = 17500$ N at 5 bar operating pressure
(from section 5.2 Table "Technical Data")

6.5.2.2 Calculation of the stopping distance

Checking the selected brake size

System distance (distance up to start of retardation)

$$S_{\text{Sys}} = V_0 \times t_{\text{Sys}} + g \times t_{\text{Sys}}^2 \times 0,5 \quad [\text{m}]$$

$$S_{\text{Sys}} = 0,5 \times 0,076 + 9,81 \times 0,076^2 \times 0,5 \quad [\text{m}]$$

$$S_{\text{Sys}} = 0,066 \quad [\text{m}]$$

$$t_{\text{Sys}} = t_{50} + t_{\text{Ventil}} = 0,060 + 0,016 \quad [\text{s}]$$

$$t_{\text{Sys}} = 0,076 \quad [\text{s}]$$

Braking distance (distance from start of retardation)

$$S_{\text{Br}} = \frac{V_{\max}^2}{2 \times \left(\frac{F_{\text{Br}}}{m} - g \right)} \quad [\text{m}]$$

$$S_{\text{Br}} = \frac{1,25^2}{12,07} = 0,129 \quad [\text{m}]$$

Stopping distance

$$S_{\text{Ko}} = S_{\text{Br}} + S_{\text{Sys}} \quad [\text{m}]$$

$$S_{\text{Ko}} = 0,129 + 0,066 = 0,195 \quad [\text{m}]$$

Stopping time

$$t_{\text{Ko}} = t_{\text{Br}} + t_{\text{Sys}} \quad [\text{s}]$$

$$t_{\text{Ko}} = 0,207 + 0,076 = 0,283 \quad [\text{s}]$$

$$t_{\text{Br}} = \frac{V_{\max}}{\frac{F_{\text{Br}}}{m} - g} = \frac{1,25}{6,03} = 0,207 \quad [\text{s}]$$

6.5.2.3 Friction Work

Friction work per braking action

$$Q_{\text{r}} = m \times g \times S_{\text{Br}} + 0,5 \times m \times V_{\max}^2 \quad [\text{J}]$$

$$Q_{\text{r}} = 800 \times 9,81 \times 0,129 + 0,5 \times 800 \times 1,25^2 \quad [\text{J}]$$

$$Q_{\text{r}} = 1637 \quad (\leq \text{permitted friction work})$$

Number of braking actions up to wear end

$$Z_{\text{zul.}} = \frac{Q_{\text{r ges}}}{Q_{\text{r}}}$$

$$Z_{\text{zul.}} = \frac{5,85 \times 10^6}{1637} = 3574 \text{ dynamic braking actions}$$

The permitted total friction work up to wear end must not be exceeded.



Please Observe!

Once the total friction work up to wear end $Q_{\text{r ges}}$ has been reached, the brake must be replaced.

Friction Work and Switching Times (Type 381.1___.) 1)			Size					
			20	30	40	60	70	80
Permitted total friction work up to wear end ²⁾	$Q_{\text{r ges}}$	106 J	0,36	0,75	1,14	3,6	5,85	10,35
Maximum permitted friction work per braking action ²⁾	$Q_{\text{r zul.}}$	[J]	240	506	760	2400	3900	6900
Brake switching time	t_{50}	[s]	0,037	0,038	0,035	0,050	0,060	0,070

1) For friction work Type 381.0___., please contact mayr® power transmission. The switching times also apply for Type 381.0___..

2) For higher friction work / total friction work, please contact mayr® power transmission.

7 Functional Safety Parameters

Consideration of the mean time to dangerous failure for ROBA[®]-topstop[®] brake systems in accordance with DIN EN ISO 13849-1 Safety of machinery – Safety related parts of control systems

The value B10d states the number of cycles until 10% of the components have suffered dangerous failures (definition acc. EN ISO 13849-1).

With regard to the brakes, these are:

- The mechanical switching process.

Here dangerous failures means that the brake does not engage on request and therefore does not generate the required nominal holding force.

The wear has no influence on this value (e.g. the wear during a dynamic braking action).

7.1.1 Functional Safety Guidelines

The brake safety is generated through the nominal holding force.

For safe and reliable braking and for error-free operation of the ROBA[®]-linearstop brakes, the following points are required:

- Sufficient dimensioning
- Intended use
- Maintenance of the application limits
- Maintenance of the technical fringe parameters



Brake dimensioning see section [6.5](#)

7.1.2 Condition



Brakes which are used in safety-related applications are to be selected in accordance with the risk assessment EN ISO 12100 and furthermore in accordance with EN ISO 13849-1 through identification of the safety function. This is in principle the task of the system manufacturer.

The Performance Level (PL) can only be determined on consideration of all safety-related parts of the safety channel such as the control and additional braking or holding devices etc. in accordance with EN ISO 13849-1.

8 Storage

8.1 Brake Storage

- Store the brakes in dry rooms, dust and vibration-free.
- Relative air humidity < 50 %.
- Temperature without major fluctuations within a range from –30 °C up to +70 °C.
- Do not store in direct sunlight or UV light.
- Do not store aggressive, corrosive substances (solvents / acids / lyes / salts etc.) near to the brakes.

For longer storage of more than 2 years, special measures are required.

Please contact the *mayr*[®] place of manufacture.

9 Installation

9.1 Installation Conditions

Please observe before installation!

9.1.1 General



Please Observe!

The piston rod must only be loaded in the direction of motion.

In case of horizontal installation, the piston rod can be guided through a plain bearing (option).

- The brake is delivered assembled ready for installation.



Please Observe!

Leave the brake is installed condition!

- The nominal holding force is set manufacturer-side via pre-tensioning the springs (3). The set screws (2) for spring pre-tensioning are secured against distortion via Loctite 243.



CAUTION The nominal holding force might be influenced.

Customer-side turning of the set screws (2) can lead to malfunctions.

Never turn the set screws.

9.1.2 Piston Rod

Requirements on the piston rod

- For brake installation, we recommend an insertion chamfer on the brake rod of min. 3 x 20°.
- The piston rod should be installed at one end as a floating bearing.
- We recommend to stress the piston rod with tension.



Please Observe!

Please pay attention to the buckling safety on pressure-loaded piston rods!

Please observe the stroke length, the load and cylinder mounting to prevent bending or buckling of the piston rod in any stroke position.

$$F_{\max} = 2,5 \times F_{\text{Nenn}}$$



Please Observe!

The ROBA[®]-linearstop function can only be guaranteed on a proper rod surface.

Rod quality

Steel, hard chromium-plated	
Layer thickness	at least 20 µm
Diameter tolerance	h7 to f7
Surface quality	Ra < 0,4 µm
Yield point	min. 400 N/mm ² (e.g. C45)

or

Steel, hardened	
Hardness testing	at least HRC 60
Tolerance field	h7 to f7
Surface quality	Ra < 0,4 µm
Yield point	min. 400 N/mm ² (e.g. C45)

On Type 381.1_ _ , the piston rod must be dry and clean.



CAUTION The clamping effect might get influenced by friction value-reducing materials, such as lubricants, greases or separating agents - please clean, if necessary; see section 12.4

9.1.3 Controls

The *mayr*[®] company recommends the following pneumatic controls.

The piston space is filled with compressed air, thus suspending the spring force. The compressed air in the piston chamber is deduced in case of power failure. The spring force has an effect on the clamping element. The piston rod is clamped/ braked.

Switching time-related Applications



Recommendation!

For applications to optimize the switching times (reduction of the braking distance)

- ❑ Select the shortest possible conduction paths. Cross-sections and line lengths have a considerable effect on the reaction times.
- ❑ For quicker brake engagement, we recommend a quick-action ventilating valve (6) (selection depending on the compressed air connection thread).



Please Observe!

The compressed air outlet must not be affected by any additional components.

- ❑ The size and speed of the 3/2 directional control valve has an effect on the switching time.
- ❑ Use a pressure reducer (3). If the actual operating pressure is higher than the required operating pressure (see Type tag), the switching time increases.

Safety-related applications



Recommendation!

For applications to optimize the safety (in case of danger to people)

- ❑ Use a proximity switch for monitoring the switching condition (see section **10.1**)
- ❑ Please use a pressure monitoring device (pressure switch 7) additionally between the brake and the quick-action ventilating valve.

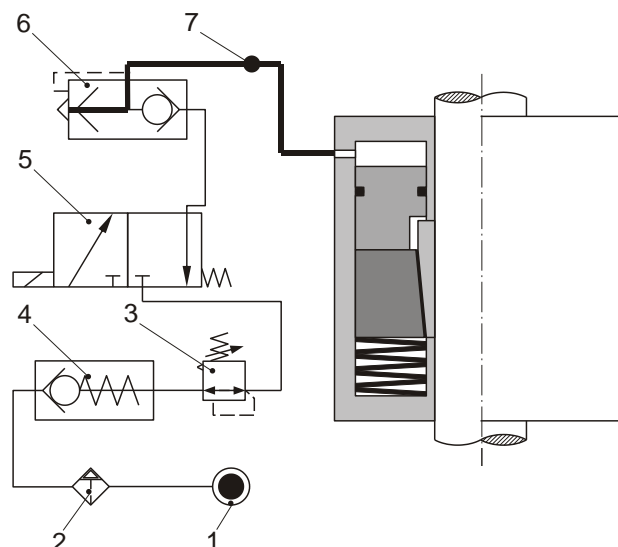

Fig. 3

Item	Name
1	Pressure source 4 – 6 bar
2	Maintenance unit
3	Pressure reducer (switching time-related application)
4	Non-return valve (in case of pressure fluctuations)
5	3/2-directional control valve
6	Quick-action ventilating valve (switching time-related application)
7	Pressure switch (safety-related applications)

9.2 Installation (Figs. 1 and 2)

9.2.1 Pre-requisites

- Unpack the brake
- Check for completeness
- Check the data on the Type tag
- Visual inspection (e.g. after longer storage period)

CAUTION Please observe the own weight of the brake



The brake may drop during lifting / disassembly. The consequences may be crush injuries and impact injuries.

9.2.2 Preparation

- Have the necessary tools ready
 - Spanners etc.
 - Torque wrenches
- Provide fixing screws (not included in the standard scope of delivery)

Fixing screw sizes and tightening torques				
Size	Thread	Tightening torque	Strength class	Screw-in depth t
20	3 x M5	5,8 Nm	8.8	13,5 mm
30	3 x M6	10 Nm	8.8	12 mm
40	3 x M6	10 Nm	8.8	12,5 mm
60	3 x M8	36 Nm	10.9	13,5 mm
70	3 x M10	71 Nm	10.9	13,5 mm
80	3 x M12	122 Nm	10.9	16,5 mm

All tightening torques are recommendations only. These data do not relieve the user from checking the data regarding the actual installation situation.



Please Observe!

It is also possible to equip the brakes with an adaptor for standard cylinders (Type 381. _ _ _ .1), see section [10.3](#).

9.2.3 Installation Procedure

1. Connect the pneumatic hose with \varnothing m1 (Fig. 1) to the compressed air connection (plug-in fitting item 6)
2. Pressurize the brake with operating pressure (see Type tag).
3. Position the mounting flange (customer-side) at the fixed bearing of the piston rod.
4. Push the brake onto the piston rod and bring it up to contact to the mounting flange (customer-side).



Please Observe!

Tilted insertion of the piston rod might cause damage to the wiper and seals. Push the brake onto the piston rod carefully.

5. Screw in the fixing screws (without torque).
6. Screw securement with Loctite 243
7. Switch the brake in de-pressurized state, thereby placing it under tension (centring).
8. Tighten the fixing screws using the torque.

9.3 Compressed air connection (not on size 20, 30)

The plug-in fitting (6) and the screw plug (7) can be swapped on the compressed air connection if necessary (difficult installation situation, lack of space etc.) (same thread).

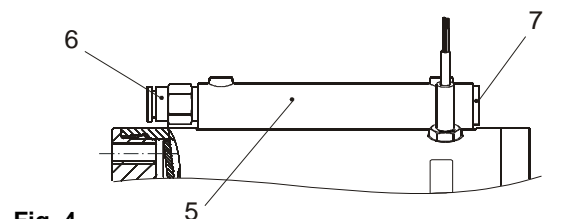

Fig. 4

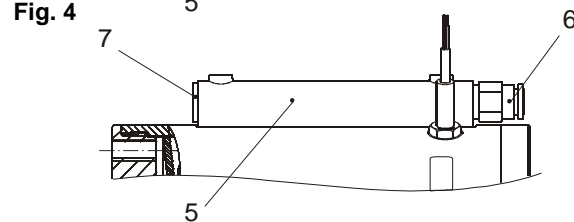

Fig. 5

Procedural Method

1. Screw out the plug-in fitting (6) and the screw plug (7) using a hexagon socket wrench.
2. Swap the positions of the plug-in fitting (6) and the screw plug (7) (Fig. 4).
3. Tighten the plug-in fitting (6) and the screw plug (7) to tightening torque (see section [5.2](#) Technical Data) (Fig. 5).



Please Observe!

Keep to the tightening torques.

If the tightening torques are not observed, there is a risk of leakage.

10 Options

10.1 Switching condition monitoring (NO contact)

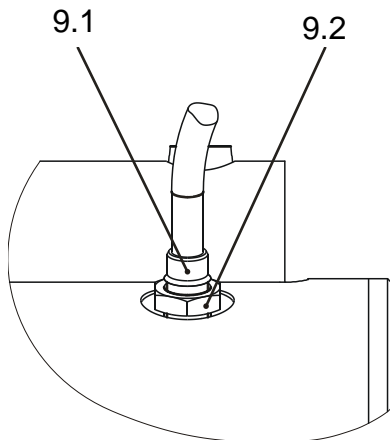

Fig. 6



Please Observe!

The switching condition monitoring is installed and set manufacturer-side.

A proximity switch (9.1) emits a signal for every brake condition change.

Plausibility check

Brake opened	Pressure switched on	Signal "OFF"
Brake closed	Pressure switched off	Signal "ON"

The customer is responsible for a signal evaluation of both conditions.

Wiring Diagram:

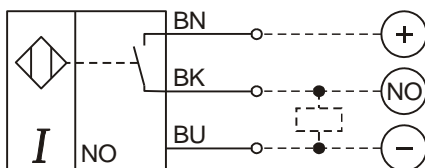

Technical Data	
PNP/NO contact	
Rated operating voltage:	$U_e = 24 \text{ VDC}$
Operating voltage:	$U_B = 10...30 \text{ VDC}$
Cable length:	2000 mm

Replacement of the proximity switch



Please Observe!

Proximity switches cannot be guaranteed fail-safe. Therefore, please ensure appropriate access for replacement or adjustment.

Pre-requisites

- Load must be secured (e.g. on vertical axes).

WARNING Load crash possible



Gravity loaded axes must be secured before beginning the work: this secures them against dropping.

- Brake is pressureless (enclosed) on the piston rod.

De-installation

Unscrew the hexagon nut (9.2), unscrew and remove the proximity switch (9.1).

Installation and Adjustment

Initial position: Proximity switch → Signal "OFF"

Activity	Result
1. Screw the proximity switch in carefully	Signal "ON"



Do not screw in the proximity switch up to its limit or do not leave it screwed in up to its limit.

2.	Counter the proximity switch (9.1) with the hexagon nut (9.2) (tightening torque see section 5.2)	
3.	Adjust the operating pressure	Signal "OFF"
4.	Carry out a functional inspection	
4.1	Switch off the pressure	Signal "ON"
4.2	Switch on the pressure	Signal "OFF"
5.	Mark the hexagon nut (9.2) with sealing lacquer	

10.2 Wear Monitoring

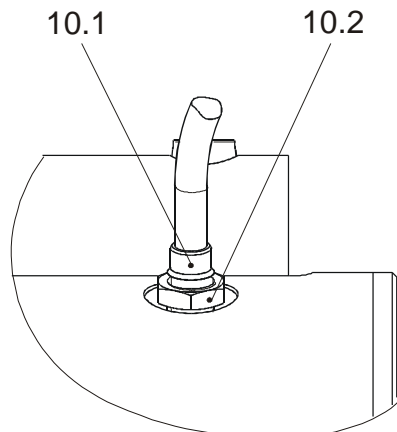

Fig. 7



Please Observe!
The wear monitoring is installed and set manufacturer-side.

A proximity switch (10.1) emits a signal change when the wear end of the brake has been reached.

Wear limit not reached	Signal "ON"
Wear limit reached	Signal "OFF"

WARNING Load crash possible
Nominal holding force not reached
Replace brake



The customer is responsible for a signal evaluation of both conditions.

Wiring Diagram:

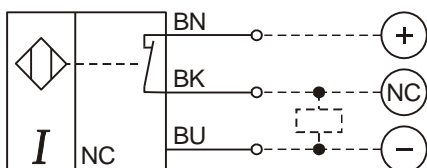

Technical Data	
PNP/NC contact	
Rated operating voltage:	$U_e = 24 \text{ VDC}$
Operating voltage:	$U_B = 10...30 \text{ VDC}$
Cable length:	2000 mm

Replacement of the proximity switch



Please Observe!
Proximity switches cannot be guaranteed fail-safe. Therefore, please ensure appropriate access for replacement or adjustment.

Pre-requisites

- Brake is de-installed (see section 13 "De-installation").

CAUTION Load crash possible



Gravity loaded axes must be secured before beginning the work: this secures them against dropping.

- Brake is depressurized (closed) **without** piston rod.

De-installation

Hexagon nut (10.2) unscrew, proximity switch (10.1) herausschrauben und entnehmen.

Installation and Adjustment

Initial position: Proximity switch → Signal "OFF"

Activity	Result
1. Screw the proximity switch in carefully	Signal "OFF"



Do not screw in the proximity switch up to its limit or do not leave it screwed in up to its limit.

2.	Counter the proximity switch (10.1) with the hexagon nut (10.2) (tightening torque see section 5.2)	
3.	Adjust the adjusting pressure of the brake Adjusting pressure = operating pressure	Signal "ON"
4.	Push the brake onto the piston rod	
5.	Switch off the pressure	Signal "ON"
6.	Mark the hexagon nut (10.2) with sealing lacquer	

10.3 Adaptor for Standard Cylinder acc. ISO 15552

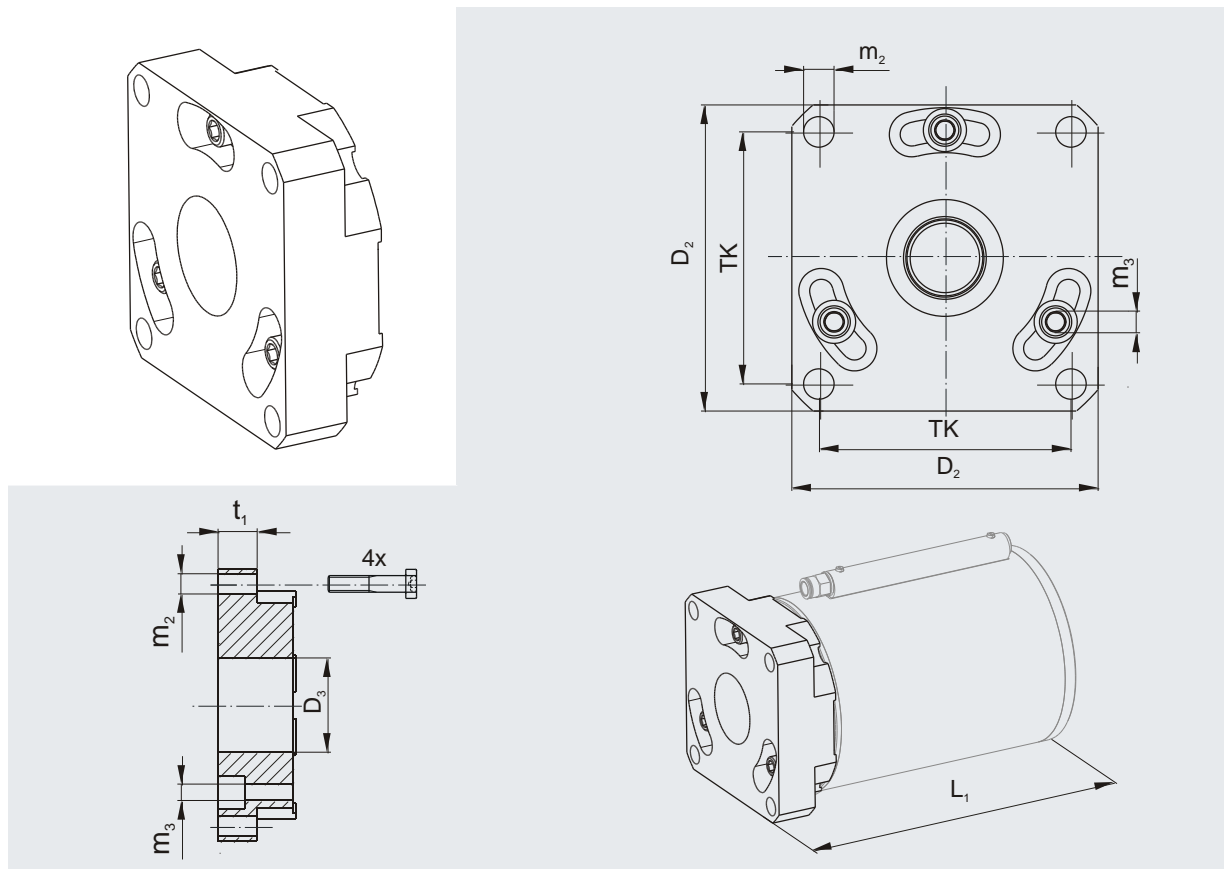

Fig. 8

10.3.1 Dimensions Sheet

			Size					
			20 ⁶⁾	30	40	60	70	80
D₂		[mm]	-	65	72,5	109	136	175
D₃		[mm]	-	40,5	45,5	55,5	60,5	65,5
L₁		[mm]	-	L ⁴⁾ + 39	L ⁴⁾ + 30	L ⁴⁾ + 39	L ⁴⁾ + 48	L ⁴⁾ + 57
t₁		[mm]	-	13	19	20	26	28
Tk		[mm]	38	46,5	56,5	89	110	140
m₂	Fixing screws 5) (not included in delivery)		4xM6	4xM8	4xM8	4xM10	4xM12	4xM16
	Tightening torque	[Nm]	-	24	24	48	83	200
m₃	Fixing screws		-	3xM4	3xM6	3xM8	3xM10	3xM12
	Tightening torque	[Nm]	-	2,7	8,4	32	63	122
Suitable for standard-based cylinder [piston Ø]			40	50	63	100	125	160

⁴⁾ For Dimension L, see section **5.3** Dimension sheet

⁵⁾ Strength class 8.8

⁶⁾ In preparation

11 Initial Operation / Operation

11.1 Brake Inspection (Before Initial Operation)

- Check all fixing screws for the required tightening torque.
- Visual inspection of the pneumatic connections and lines.
- Check for leakages (on pressurization).

11.2 Brake Test (initial operation)

CAUTION



During the Brake Test danger to personnel and damage to machines cannot be ruled out in case of malfunctions (incorrect installation, control errors etc.).

Do not enter the danger zone.
Possibly take measures for catching or damping the load.

Check dimensioning!

11.2.1 (Static) Brake Inspection

- On vertical axes, a brake inspection is carried out via load assumption or via the drive.



Recommendation!

Test the brake using the nominal holding force or the maximum load mass.

11.2.2 (Dynamic) Brake Test

Type 381.1 _ _ _



Recommendation!

On gravity-loaded axes with increased risk (application of the risk evaluation acc. EN ISO 12100), we strongly recommend a brake test during the initial operation of the machine. Determine the braking distance in a brake test during initial operation and compare it with the calculated braking distance → EN ISO 13855/EN ISO 13849-2. This test is meant to test the actual braking distance with the maximum movement speed and the respective load masses.

The determined braking distance must be shorter than the calculated braking distance.

If the stopping distance is not sufficient, please see Malfunctions / Breakdowns, section 15.

11.3 Brake Inspection (during operation)



Recommendation!

A test must be carried out to guarantee the necessary holding force with all control and brake times if a risk is generated by gravity-loaded axes. A cyclic brake inspection during running operation provides additional safety. Depending on the danger, please observe the respective regulations and standards.

11.3.1 Regular Function Inspection (static)

- Depending on the application requirements, we recommend carrying out regular braking force inspections (depending on the application), e.g. check the static holding force 1 x per shift with nominal holding force or with maximum load mass.
- In addition to the regular inspection of the holding force, we recommend the application of a switching condition monitoring device (option), in order to request the brake switching condition or to prevent a possible load crash on vertical installation.



Recommendation!

The holding force may be reduced by friction value-reducing materials. If the brake during the functional inspection does not achieve the nominal holding force, repeat using the maximum load mass and clean the piston rod at the next opportunity (see section 12.4).

11.3.2 Regular Functional Inspection (dynamic)

Type 381.1 _ _ _

- Check the braking distance regularly.

Operational Instructions for ROBA[®]-linearstop Type 381. _ _ _ _ Sizes 20 – 80

(B.381.1.EN)

12 Maintenance / Inspection / Switching Frequency

12.1 Switching Frequency

The ROBA[®]-linearstop is designed for a switching frequency of up to 2 million switching actions.



At a switching frequency > 200.000, a reduction in nominal holding force of -20 % must be expected.

12.2 Inspection

Check the condition

Measure	Condition		Interval	Implementation
Visual inspection	Wiper	The wiper must not show any signs of wear, as otherwise there might be a risk of dirt penetration	To be determined by machine operator depending on the installation situation ► Please contact <i>mayr</i> [®] .	Qualified personnel
	Pneumatics	Check that the connections and connection lines are leak-proof.		
	Piston Rod	Type 381.0_ : Check the piston rod for wear.	After every EMERGENCY STOP occurrence.	

On applications without wear monitoring (see section **10.2**):

Measure	Condition		Interval	Implementation
Visual inspection	Wear indicators	Nominal holding force is not reached (slipping). Replace brake	To be determined by machine operator depending on the installation situation ► Please contact <i>mayr</i> [®] .	Company <i>mayr</i>[®]

12.3 Maintenance

The ROBA[®]-linearstop is mainly maintenance-free.

Measure	Note/comment	Interval	Implementation
Functional Inspection	Carry out functional inspection regularly, see section 11.3	see section 11.3	Qualified personnel
Check the piston rod	The piston rod must be checked regularly for contamination with friction value-reducing materials; it must be cleaned, if necessary (see section 12.4). Special maintenance work may be necessary if the device is subject to large amounts of dirt or dust or is operating in extreme ambient conditions. Please contact the <i>mayr</i>[®] place of manufacture.	at least every 6 months	



Should the ROBA[®]-linearstop no longer meet the required characteristics or should the necessary safety for work on the machine or system no longer be given, the brake must be checked at *mayr*[®] and, if necessary, professionally repaired and approved.

12.4 Cleaning:

Clean the piston rod using ethyl alcohol.

13 De-installation

WARNING Load crash possible



The brake must be load-free.
Please check that it is load-free before
de-installation.

Provide security in the danger zone.
Support the load

CAUTION Please observe the own weight of the brake



The brake may drop during lifting / disas-
sembly. The consequences may be crush
injuries and impact injuries.

De-installation takes place by following the "Installation
Procedure" section **9.2.3** backwards.

14 Disposal

For disposal, please observe the specific regulations of
the respective country of application.

Electronic Components (Proximity switch):

Products which have not been disassembled can be
disposed of under Code No. 160214 (mixed materials) or
components under Code No. 160216, or can be disposed
of by a certified disposal firm.

All steel components:

Steel scrap (Code No. 160117)

Seals, O-rings, V-seals, elastomers:

Plastic (Code No. 160119)

15 Malfunctions / Breakdowns

Malfunction	Possible Causes	Solutions	Implementation
Brake does not release	Operating pressure too low	Check operating pressure and increase if necessary	Qualified personnel
	Defective valve	Replace defective valve	
	Changed spring pre-tensioning	Send the brake to the manufacturer	Company mayr[®]
Brake does not brake	Brake wear limit reached	Replace brake	Qualified personnel
	Defective valve	Replace defective valve	
	Piston rod too small	Check dimensioning, check technical data	
Braking distance too long	Friction value-reducing materials on the piston rod	Clean the piston rod	Qualified personnel
	Incorrect dimensioning	Check dimensioning, check technical data	
	Valve too slow		
	Quick-action ventilating valve too small		
Switching condition monitoring device does not provide signal	Line between brake and quick-action ventilating valve too long		Qualified personnel
	Brake does not release	See Malfunctions → Brake does not release	
	Defective cable	Replace defective cable	
Wear monitoring without signal	Defective INI (proximity switch)	Replace defective proximity switch	Qualified personnel
	Defective cable	Replace defective cable	
	Defective INI (proximity switch)	Replace defective proximity switch	
Wear monitoring without signal	Defective cable	Replace defective cable	Company mayr[®]
	Defective INI (proximity switch)	Replace defective proximity switch	
	Brake wear limit reached	Replace brake	



Mayr[®] will take no responsibility or guarantee for replacement parts and accessories which have not been delivered by mayr[®], or for damage resulting from the use of these products.

16 Declaration of Conformity

EC – Declaration of Conformity

TRANSLATION

In terms of the EC Directive 2006/42/EC (machinery directive) relating to machinery we

**Chr. Mayr GmbH + Co. KG
Eichenstraße 1
D-87665 Mauerstetten**

declare that the products stated below have been developed, constructed and manufactured in sole responsibility and in conformity with the above mentioned EC Directive.

Pneumatic piston rod brake

Product	Sizes	Types	ASRI
ROBA®-linearstop	20 - 80	381.1 _ _ _ _	1,2,3,4 *

Year of manufacture: see product label

Applied Standards, Regulations and Inspections (ANVP)

1	DIN EN ISO 4414	04/2011	General rules and safety requirements for pneumatic systems	2006/95/EC
2	DIN EN ISO 12100	03/2011	Safety of machinery - General principles for design	2006/42/EC
3	DIN EN ISO 13849-1	12/2008	Safety of machinery – Safety related parts of control systems	2006/42/EC
4	GS-BIA-M08	08/2012	Principles of testing and certification of pneumatic fluid power emergency-brake systems with holding force function for linear movement	

The safety of our customers and machinery operators is important for the company Chr. Mayr GmbH + Co. KG. Therefore the product has been additionally tested by an independent certification body TÜV SÜD, identification number KP 136. Based on GS-BIA-M08 “Principles of testing and certification of pneumatic fluid power emergency brake systems with holding force function for linear movement”.

X	* EC-Machinery directive 2006/42/EC
	** EC-Low voltage directive 2006/95/EC (is covered by the machinery directive)
	*** Electromagnetic compatibility directive 2004/108/EC

Representatives name for the documentation: Quality Management

Mauerstetten, February 27, 2013
Ort und Datum / place and date

Dipl. Ing. (FH) / Graduate Engineer
Geschäftsführer / Managing Director
Günther Klingler